

Introduction to the storage and installation of Trussed Rafters on site

Introduction

Trussed Rafters can vary significantly in size and weight, see the TRA website for more information and common examples. Your chosen TRA member will provide information about size, weight and lifting points specific to the trussed rafters you have ordered.

During handling and storage, vertical Trussed Rafters are potentially unstable and must always be supported and or restrained to prevent them toppling over putting staff and others at risk. Such support and restraint is categorised as Temporary Works and therefore must be approved and recorded by the defined temporary works co-ordinator, where necessary with input from a temporary works engineer.

Unloading Trussed Rafters

When a delivery of trussed rafters arrives on site the contractor(s) involved should be prepared and have already allocated sufficient and suitable resources to ensure the trussed rafters are unloaded safely.

This operation will have been subject to a Contractors General Risk Assessment and then detailed in a safe working method statement that has been approved by the principal contractor or the person responsible for Health and Safety on site. TRA have produced information sheets about unloading to assist with this documentation. Contractors should contact their chosen TRA member to access this information and confirm delivery requirements.

Trussed rafters will be delivered in tight bundles using bindings. This will require mechanical handling equipment, such as a forklift or crane, to enable the safe manoeuvring of these large units. The safe working method statement should accommodate any special handling instructions or hazards specified by the designer in the risk assessment for the truss design.

Site Storage of Trussed Rafters

Trussed rafters can be safely stored vertically or horizontally at ground level or on any other properly designed temporary storage platform above ground level. Whichever method and location is chosen the temporary support must ensure the bundled or individual trussed rafters are fully supported and restrained to prevent them toppling over putting staff and others at risk. Such storage should also be set out to ensure that the units do not make direct contact with the ground or any vegetation and be so arranged as to prevent distortion.

The delivery of trussed rafters should, wherever possible, be organised to minimise site storage time; however, where longer periods of storage are anticipated then the trusses should be protected with covers fixed in such a way as to allow proper ventilation around the trusses.

When stored vertically bearers should be positioned at the locations where support has been assumed to be provided in the design with stacking carried out against a firm and safe support or by using suitable props (Fig. 1). In both cases the support must be appropriate for the size and weight of trussed rafters being stored.

Fig 1: Safe vertical storage



When trusses are stored horizontally level bearers should be positioned beneath each truss node as a minimum. (Fig. 2). Other methods of storing trussed rafters may cause deformation and distortion unless specific provision has been made in the design for an alternative temporary support load case.

Fig 2: Safe horizontal storage

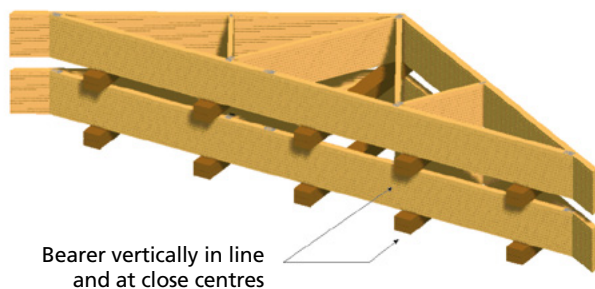

Extreme care should be exercised when removing the bindings from a bundle of trusses in the vertical position. As a precaution against destabilisation of the whole bundle of trusses, it is recommended that prior to the removal of the bands, timber battens are fixed across the bundle at several locations with a part driven nail into every truss. Such a simple precaution will allow the safe removal of single trusses once the bands are removed. An example is illustrated in Fig. 3.

Fig 3: Safe method of breaking a bundle of trusses

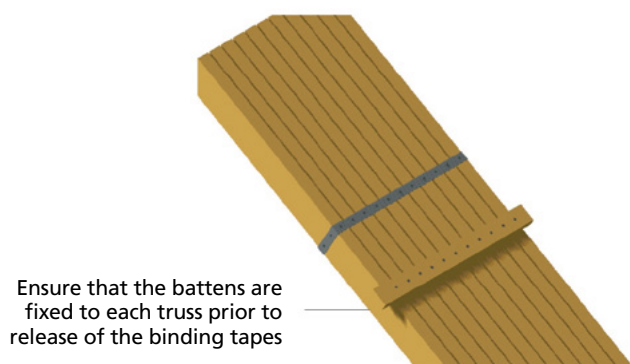

Installation of Trussed Rafters

Installing trussed rafters requires specific construction skills which involve working at height handling dynamically unstable materials and should only be undertaken by suitably experienced and qualified personnel such as those with a Level 2 Diploma in Site Carpentry. The contractor responsible for installation should undertake a full site-specific risk assessment and develop a safety method statement before any work commences. These documents shall include details of the temporary support essential during the initial installation stage.

A safe working platform should be provided around the perimeter of the roof using edge protection boarded scaffold with guard rails and suitable safe access onto the roof, e.g. a stair tower.

Measures to prevent or mitigate the distance of a fall, should one occur, must also be provided internally. This can be achieved by providing a working platform or 'crash deck' immediately beneath the underside of the trusses. Either conventional scaffolding, or proprietary decking systems can be used for this purpose. Systems such as nets or air and bean bags should only be relied on where a working platform described above is not feasible.

The Work at Height Regulations specifically require weather conditions to be considered when planning any work. Wind loading presents a particular risk for trussed rafters that are not installed and fully braced. TRA would support the NFRC recommendation that roof installation activity involving components greater than 5m long should cease when the mean wind speed reaches 17 mph (gusting to 26 mph or over)

The principle to achieve stability during installation is to create a group of trusses that when suitably braced form an independent self-supporting unit. This unit usually of three or more trussed rafters @ 600mm c/c can be assembled in situ at roof level or with suitable planning be pre-assembled at ground level and craned into place on the roof. Once in place this unit provides a stable base from which further trussed rafters can be braced.

The larger the truss being installed the stronger the temporary bracing necessary to provide support. A practical minimum would be C16 strength class the same thickness as the trussed rafter (36 or 47mm) x90mm wide. No piece of temporary bracing should be less than 1500mm long allowing fixing to a minimum of three trussed rafters. Always ensure the correct fixings are used to secure

Temporary bracing of trussed rafters at roof level or any form of pre-assembly at ground level are Temporary Works and must be approved and recorded by the defined temporary works co-ordinator, where necessary with input from a temporary works engineer.

Installation Procedure Simple Domestic Roofs

The following gives guidance on a typical erection sequence for a simple domestic type roof. Diagrams are for illustration only, with perimeter scaffolding and internal working platform not shown.

Step 1

Ensure wall plates are level and adequately secured to load bearing walls. Mark off positions of trusses along both plates.

Step 2

Either mechanically or manually lift the first truss up to the roof holding it in a vertical plane. Erect the first truss in such a way that it coincides with the position of the end of the rafter diagonal bracing when fitted. Temporarily brace first truss to both wall plates (Fig. 4) ensuring the correct size of bracing and fixings specified in the temporary works plan are used.

Fig 4

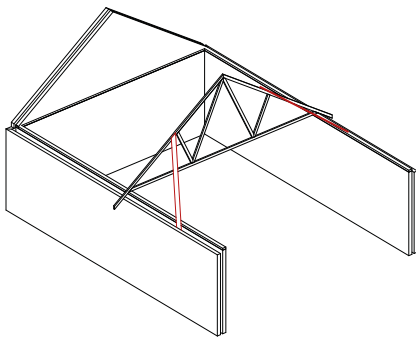

Step 3

Erect second truss ensuring that its production face matches the first truss as indicated by the labels or markings affixed to the truss. Then brace back to first truss with temporary horizontal bracing along both the rafters and ceiling tie members, ensuring both trusses are vertical (Fig. 5).

Fig 5

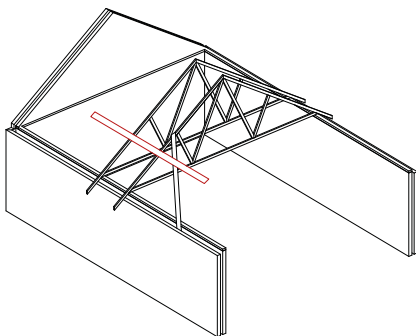

Step 4

Erect third truss towards gable end ensuring correct orientation of common manufacturing faces as described above. Check vertical and fix to installed temporary bracing along both the rafters and ceiling tie members to create a stable unit. Erect further trussed rafters with temporary bracing back to this stable unit.

Step 5

Fix the permanent diagonal braces (Fig. 6) to the inner face of the rafters at approximately 45°, nailed to the wall plate at the lower end and fixed as high up the first truss as possible leaving space for the apex longitudinal brace. All permanent braces should be minimum 22 x 97mm timber, dry and free of major defects. Fixed to each truss with 2 no. 3.1 mm x 65 mm long mechanically driven gun nails or 3.35mm dia. x 75mm long galvanized nails. Braces may be jointed providing the lap spans at least two trusses.

Fig 6

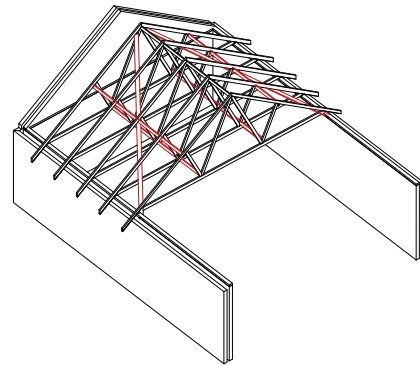

Step 6

Fix remaining longitudinal bracing to rafters, struts and ceiling ties as shown in Fig. 6. Note that all bracing is repeated for both sides roof.

Step 7

Temporary bracing can now be removed, and any additional trusses erected using the completed section of the roof as a means of temporarily bracing them.

Step 8

All remaining longitudinal diagonal and chevron bracing specified for the roof should now be fixed, along with galvanized metal retaining straps to walls and gable ends. The upper section of two part "Top Hat" trusses can now be installed.

Step 9

After erection and before felting and battening the roof, check that all trusses are aligned vertically, and each truss is restrained from bowing out of its vertical plane.

Access to High Level Bracing

The installation contractors full site-specific risk assessment and safe method statements shall include consideration and details for safe access to high level truss bracing and “top hat” installation. Both of which are essential elements of trussed rafter design.

Such access can be safely achieved using proprietary equipment such as “DTE Safe Step” or “STA Safe access system”.

Alternately, if requested during order stage additional timber members can be incorporated within the trussed rafter design to provide support for temporary access platforms.

Trusses should never be cut or adjusted in any way. If site circumstances make modification unavoidable then changes should only ever be made with the prior knowledge and consent of the trussed rafter designer.

This information sheet gives a brief introduction to the storage and erection of trussed rafters on site for a simple house roof. It is not intended to be comprehensive and it is accepted that there may be many other solutions to the various aspects of construction discussed. Readers are advised to discuss their design situations with their specialist trussed rafter supplier.

Do's and don'ts on site - If in doubt - ask

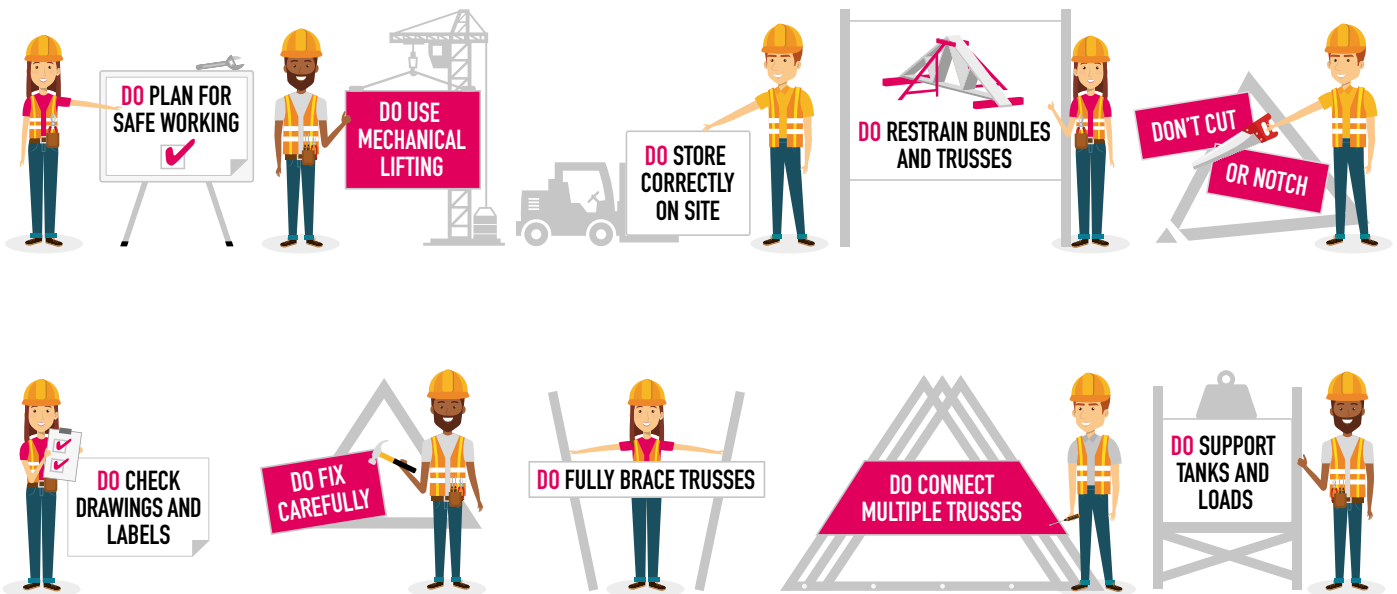

The guidelines contained within this information sheet are given in good faith but without liability and its use shall be entirely at the risk of the user.