



Mitek[®]

The World of Posi Technology

**The Posi-Joist
Technical Handbook
Issue 7**

CONTENTS

Introduction

- 3** [An Introduction to Posi-Joists](#)
-

Floor Applications

- 8** [Intermediate Floor Applications](#)
 - 14** [Posi-Joist Standard Details](#)
 - 24** [Separating Floor Applications](#)
 - 27** [Separating Distance in Timber Frame Construction](#)
 - 29** [Ground Floor Applications](#)
 - 31** [Site Practice and Handling](#)
-

Roof Applications

- 38** [Posi-Rafters](#)
 - 39** [Posi-Rafter Standard Details](#)
 - 40** [Posi-Attic Trusses](#)
-

Wall Applications

- 41** [Wall Applications](#)

An Introduction to Posi-Joist

The Metal Web Joist system

You simply can't afford to ignore the advantages of the Posi-Joist system.

Posi-Joist combines the lightness of timber with the strength of the Posi-Strut steel web allowing you to span far greater distances than would be possible with alternative timber products.

This gives you unequalled design freedom across a wide range of applications for both floor and roof in domestic, industrial and commercial applications. The Posi-Joist allows a variety of internal room layouts within an external shell due to its clear spanning capabilities.



Easy access for the installation and maintenance of the services in the floor zone is the clear advantage of the Posi-Joist system, and with the ever increasing need for MVHR (Mechanical Ventilation and Heat Recovery) systems, Posi-Joist provides a perfect and simple solution that just isn't possible with alternative solid timber products.

Posi-Joist can be specified in a wide range of depths and specifications:

Web Type	Clearance between flanges	Standard Depth
PS8	108mm	202mm
PS9	131mm	225mm
PS10	159mm	253mm
PS12	210mm	304mm

Web Type	Clearance between flanges	Standard Depth
PS14	279mm	373mm
PS16	327mm	421mm

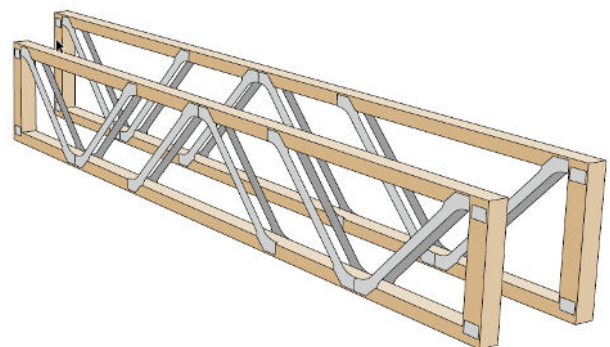
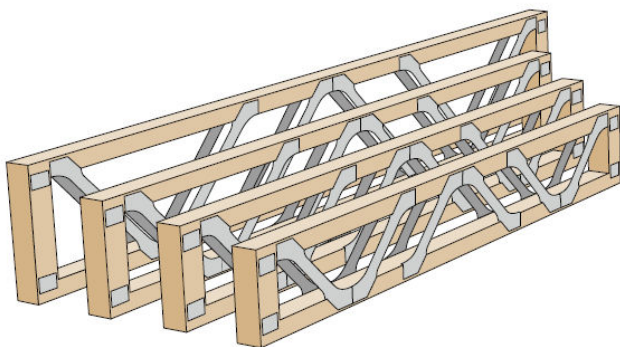

Economy

Whilst an initial linear metre cost comparison with solid joist alternatives may suggest otherwise, Posi-Joist's ability to span greater distances than its timber competitors, coupled with its open web design gives the contractor several important cost saving advantages. The installation of services and utilities is far simpler and quicker with Posi-Joists, reducing both labour costs and build-up time on site.

Joists are manufactured in a controlled offsite environment ensuring a quality product, and are delivered 'made to measure' allowing for speedy erection. What's more, Posi-Joists will often eliminate the need for load-bearing intermediate walls, dramatically cutting overall building costs.

To check a span and see a range of suitable Posi-Joist specifications visit www.mitekposi.co.uk to use our interactive span tables.

Performance

Exceptional floor performance from a wide fixing surface makes flooring easy, controls shrinkage and with precision engineering it all reduces those tiresome return visits and remedial work.

More benefits such as the unique open web design provide an area in which Plumbers, Electricians and Mechanical Ventilation and Heating Contractors will find it easy and convenient to work.

The job's done far more quickly and the contractor makes worthwhile savings.



Manufacturers

With the largest network of licensed fabricators across the UK and Ireland, you are never too far from a Posi-Joist manufacturer.

All manufacturers use the very latest BIM compliant MiTek 3D Design and Engineering software and are able to provide clear and detailed drawings.

To find your nearest manufacturer visit www.mitek.co.uk/manufacturers



Efficiency

Posi-Joist can adequately span for floors and for flat and pitched roofs, often allowing for increased joist centres when compared to alternative systems.

It's span capability and wide timber flanges make it the more desirable alternative to all steel systems.



Flexibility

Design flexibility is inherent in the concept of the Posi-Joist. The depth, length and width can be adjusted to produce an enormous number of different specifications, each with clearly defined performance criteria. In addition, end details of the Posi-Joist can be altered to give a variety of support conditions.

You will never come up short with the Posi-Joist Trimmable End. Each end can incorporate a solid timber block which can be engineered with up to 130mm allowance for trimming on site.

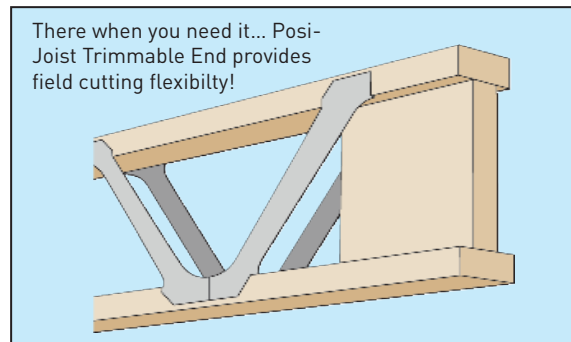

No blocking or herring bone strutting is necessary with the Posi-Joist system. Instead a strongback installed near midspan (see page 21 for details) provides a much more effective load transfer system between adjacent joists.



Material Savings

Tested by TRADA, included in ETA 07/0161 and accepted by NHBC, staggered Posi-Strut webbing reduces the material content of the joist providing economic and environmental savings.

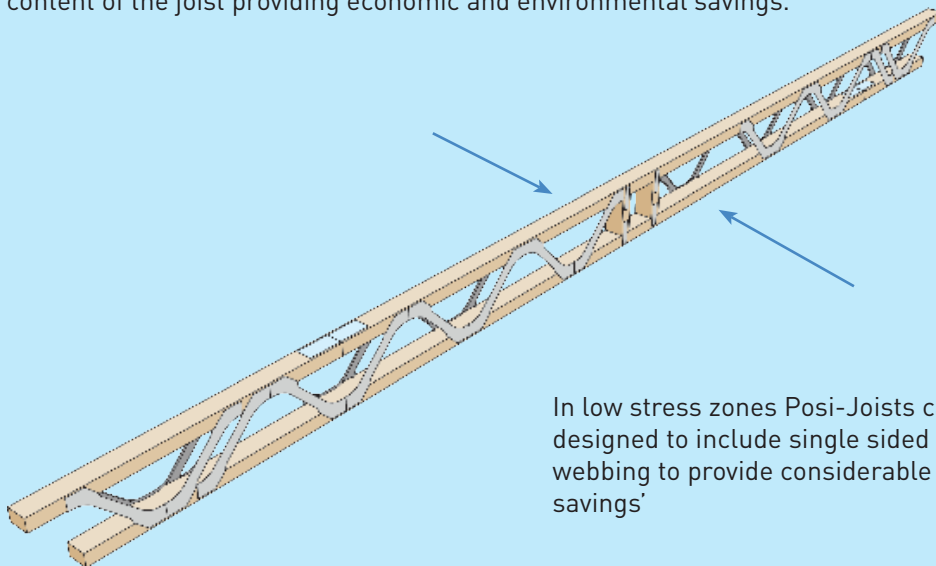

In low stress zones Posi-Joists can be designed to include single sided Posi-Strut webbing to provide considerable material savings'

Posi-Joist is a fully tested product with a European Technical Approval ETA-07/0161. Fire resistance tests for 30, 60 and 90 minutes have successfully been carried out.

Intermediate Floor Applications



Typical construction details

Posi-Joists can be built into the inner leaf of an external cavity wall as illustrated. This method of construction meets the thermal and air leakage requirements of Building Regulations provided that the perimeter of the Posi-Joist is sealed with silicone sealant as shown and the wall is insulated to the Building Designer's specification. Alternative proprietary built-in constructions may be used, such as joist 'end caps', provided that they have been shown by third party tests to meet or exceed the air leakage performance of the construction illustrated. The construction illustrated provides lateral restraint to the wall.

Note: Certain 'end caps' may not provide lateral restraint to the wall, and restraint straps may therefore be required.

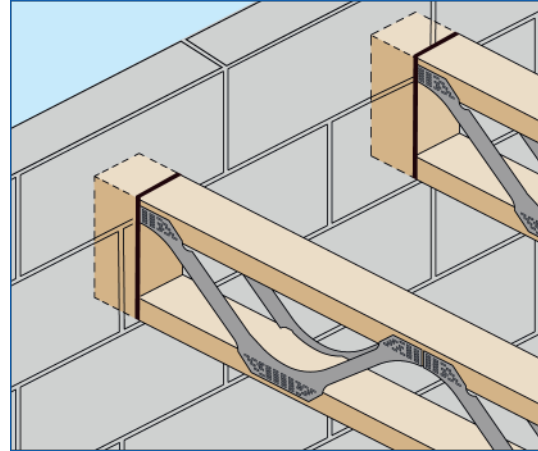

Block work to continue between Posi-Joists to provide restraint. Note: This is not allowed on solid external walls

Posi-Joists can be supported in masonry hangers at an external masonry wall. This method of construction meets the thermal and air leakage requirements of Building Regulations.

This detail does not provide lateral restraint to the wall unless a restraint type hanger is used, if standard masonry hangers are used restraint straps will be required.

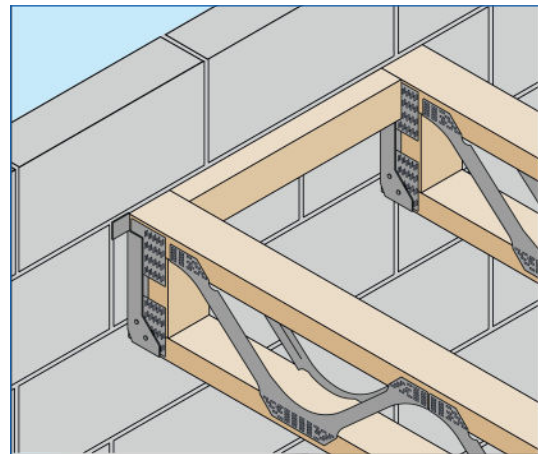

Top Chord restraint fixed between Posi-Joists to provide restraint. (Choose correct hanger for load, bearing width and coursework level)

This detail illustrates a popular construction detail for supporting Posi-Joists at an external timber frame wall. This construction meets the thermal and air leakage requirements of Building Regulations provided that the floor edge is insulated by a material with a minimum R-value of 0.75m² K/W and that a bead of sealant is placed between the skirting board and the floor deck and that an effective air barrier is maintained within the floor zone by means of solid noggins or header joists. The construction provides lateral restraint to the wall provided that the connection is designed and detailed by the Building Designer.

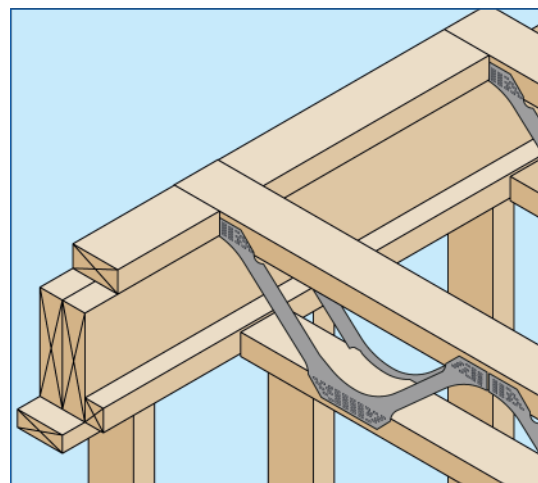

Fire resistance

The requirement for fire resistance of domestic intermediate floors is normally 30 minutes and this is provided almost entirely by the ceiling plasterboard. The responsibility for specification of the plasterboard and its fixings rests with the Building Designer.

Posi-Joist floors with a variety of build-ups have been independently tested to both BS and EN Standards and those Posi-Joist floors providing 30 minutes fire resistance are listed in the tables below.



The following table describes Posi-Joist floors providing 30 minutes fire resistance to BS476-21

Fire Resistance	Max Joist Centres	Joist Depths	Ceiling details	Floor deck details
30 minutes	600mm	All depths ≥ 225 mm	15mm Type A plasterboard (wallboard)	22mm chipboard
30 minutes	600mm	All depths ≥ 225 mm	12.5mm Type A plasterboard (wallboard) with 5mm plaster skim	22mm chipboard

The following table describes Posi-Joist floors providing 30 minutes fire resistance to EN1365-2/EN13501-2

Fire Resistance	Max Joist Centres	Joist Depths	Ceiling details	Floor deck details
30 minutes	400mm	All depths ≥ 225 mm	15mm Type A plasterboard (e.g. wallboard) [drywall screws at 150mm (perimeter)/230mm (internal) centres]. No room perimeter plasterboard noggins.	22mm P5 particleboard (chipboard), 18mm OSB/3 or 18mm flooring grade softwood plywood deck, either screwed or glued and screwed to joists
30 minutes	400mm	All depths ≥ 225 mm	12.5mm Type A plasterboard (e.g. wallboard) [drywall screws at 150mm centres] with 5mm plaster skim	18mm or 22mm P5 particleboard (chipboard), 18mm OSB/3 or 18mm flooring grade softwood plywood deck, either screwed or glued and screwed to joists
30 minutes	600mm	All depths ≥ 225 mm	15mm Type F plasterboard (e.g. fireline) [drywall screws at 230mm centres]	22mm P5 particleboard (chipboard), 18mm OSB/3 or 18mm flooring grade softwood plywood deck, either screwed or glued and screwed to joists
30 minutes	600mm*	All depths ≥ 225 mm	15mm Type A plasterboard (e.g. wallboard) [drywall screws at 150mm centres]	22mm P5 particleboard (chipboard) glued and screwed to joists

* - Minimum 47x97mm Strongback

Fire resistance tests undertaken on Posi-Joist floors, in which the ceiling has been penetrated by downlighters and ventilation services, has shown that 30 minutes fire resistance can be maintained with appropriate intumescent protection at ceiling penetrations.

For ceilings with service penetrations, MiTek recommends that for joists at 600mm centres 15mm Type F plasterboard is used whilst for joists at 400mm centres 15mm Type A plasterboard may be used.

Further details can be provided upon request.

Sound resistance

United Kingdom (excluding Scotland)

The requirement for sound resistance of floors in England, Wales and Northern Ireland is that they should achieve an airborne sound resistance of 40dB based on laboratory tests.

Scotland

The requirement for sound resistance of floors in Scotland is that they should achieve an airborne sound resistance of 43dB based on laboratory tests.

Republic of Ireland

There are no sound resistance requirements for intermediate floors.

The following table provides details of Posi-Joist acoustic laboratory test results

Floor Build-up	Weighted Airborne Sound Reduction dB	UK (exc. Scotland) Min 40dB	Scotland Min 43dB
202mm Posi-Joist, 22mm chipboard walking surface, 100mm mineral wool insulation, 15mm gypsum wallboard	40	✓	✗
202mm Posi-Joist, 22mm chipboard walking surface, 100mm mineral wool insulation, 12.5mm gypsum wallboard	42	✓	✗
225mm Posi-Joist™, 22mm chipboard walking surface, no insulation, 15mm gypsum wallboard	42	✓	✗
225mm Posi-Joist™, 22mm chipboard walking surface, 100mm mineral wool insulation, 15mm gypsum wallboard	44	✓	✓
253mm Posi-Joist™, 18mm plywood walking surface, 100mm mineral wool insulation, 15mm gypsum wallboard	41	✓	✗
253mm Posi-Joist™, 22mm chipboard walking surface, no insulation, 15mm gypsum wallboard	43	✓	✓
253mm Posi-Joist™, 22mm chipboard walking surface, 100mm mineral wool insulation, 15mm gypsum wallboard	44	✓	✓

Note: Gypsum Wallboard ceiling used fixes to the Posi-Joists at 300mm centres using 38mm Gyproc drywall timber screws.

Floor design considerations

Deflection

EC5 requirements

Deflection limits are given in the National Annex to EC5. For joists with plasterboard ceilings a limit of span/250 is applied to the final deflection (sum of instantaneous and creep deflections).

Options to limit deflection

The designer is able to produce a floor with improved vibrational performance by applying additional or stricter limits on deflection than the Code-based limits. This can be done by decreasing the limit on final deflection or more commonly by restricting the instantaneous deflection to an absolute value.

Vibration

The procedures and limits for the control of vibrations in floors are given in the National Annex to EC5. The procedures are two-fold:

- Ensuring the fundamental frequency of the floor, under dead load only, exceeds 8 Hz.
- Limiting the deflection occurring under a 1 kN point load'

Loadings

Dead Loads

Dead load should account for the weight of all building materials in the floor. It is made up of all the layers in the floor makeup, ceiling linings and insulation and self-weight of the Posi-Joist. The TRA recommends a minimum combined floor and ceiling dead load of 0.41 kN/m², which is the normal weight of a standard floor used in houses.

Imposed Loads

The floor imposed load is an estimated kN/m² (area) value that is made up of people and furniture based on what function the floor is intended for. For example, office loading takes into account heavy items such as filing cabinets, whereas domestic house loading will only take into account lighter furniture. The amount of people expected to use the floor space also plays a role in determining the value of the imposed floor loading. EN1991-1-1 gives the load that should be applied for different building usage. The table opposite shows typical values.

Partition Loads

Partition load is to take into account the self-weight of lightweight internal walls that may sit on top of the floor. The TRA recommends that a blanket load of 0.35 kN/m² is applied to the floor as the position of internal walls could change over the life of the building.

Stair Loads

Where stairs are fixed to Posi-Joists dead and imposed loads should be applied to the floor. Dead load is the weight of the stairs and imposed loads is the live loading of traffic using the stairs. The load should be applied as two point loads at the head of the staircase.

Additional Loads

Additional loads could include hoist loads or wind loads, and can be applied using the tools in the MiTek design software. Please contact the MiTek design office or helpdesk for design advice if in any doubt.

Strongback

Increases in a floor's transverse stiffness (i.e. in a direction perpendicular to the joists) lead to improvements in the floor's vibrational performance. The addition of a strongback, a solid timber member running perpendicular to the Posi-Joists and connected to the Posi-Joists greatly increases the floor transverse stiffness with the attendant improvements in the floor's vibrational performance. Strongbacks should be used for all spans greater than 4m with further details given on page 21.

Typical Minimum Imposed Floor Loads to BS EN 1991-1-1

The table below summarises the most common imposed loads from the full list given in code of practice BS EN 1991-1-1. For the full list please refer to the code or contact MiTek for assistance.

Type of Occupancy	Example Usage		Uniformly distributed Load
Domestic and Residential	1	All usage within self contained dwelling units and communal areas (including kitchens) in blocks of flats with limited use*	1.5 kN/m ²
	2	Bedrooms and dormitories excluding hotels	1.5 kN/m ²
	3	Bedrooms in hotels, hospital wards, toilet areas	2.0 kN/m ²
	4	Snooker rooms	2.0 kN/m ²
	5	Communal kitchens except in flats covered in 1. above	3.0 kN/m ²
Offices	6	General office use	2.5 kN/m ²
Areas where people may congregate	7	Public, institutional and communal dining rooms, lounges, cafes and restaurants	2.0 kN/m ²
	8	Reading rooms with no book storage	2.5 kN/m ²
	9	Classrooms	3.0 kN/m ²
	10	Corridors, hallways and aisles in institutional type buildings not subjected to crowds	3.0 kN/m ²
	11	Corridors, hallways and aisles in institutional type buildings not subjected to crowds and wheeled traffic	5.0 kN/m ²
	12	Dance Halls, studios, gyms and stages	5.0 kN/m ²
Shopping areas	13	Areas in general retail shops or department stores	4.0 kN/m ²

* Communal areas in blocks of flats with limited use refers to blocks consisting of not more than three storeys and with not more than four self contained dwellings per storey accessible from one staircase

Posi-Joist Standard Details



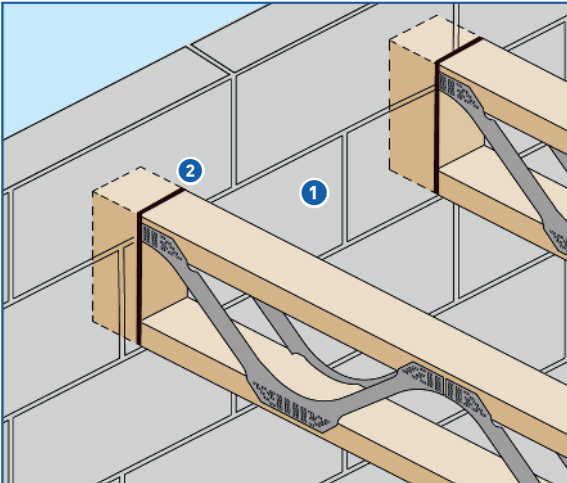

PD01: Bottom Chord Support: Built Into Masonry

- 1 Blockwork to continue between joists to provide restraint
- 2 Fully flexible sealant to provide air tightness

Parallel Restraint Straps: Ground/1st Floor not required provided min 90mm bearing. 2nd Floor at max 2.0m centres.

Note: This detail is not allowed on single skin external walls

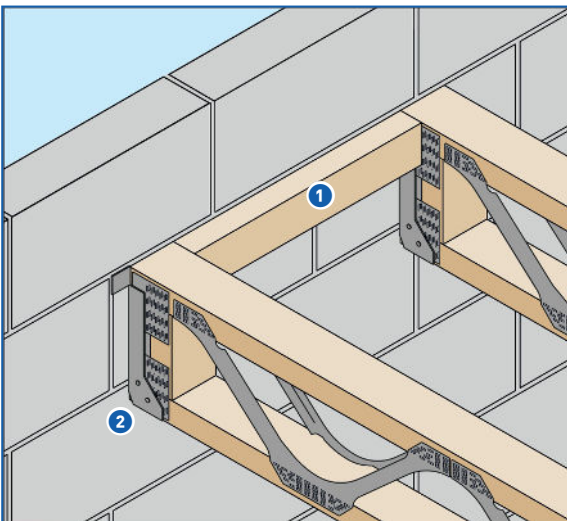

PD02: Bottom Chord Support: Masonry Hanger with Noggin Restraint

- 1 Top restraint noggins fixed between Posi-Joists
- 2 Masonry Joist Hanger. Do not notch bottom chord of Posi-Joist over bottom flange of hanger

Parallel Restraint Straps with non-restraint hanger: Ground, 1st and 2nd Floor at max 2.0m centres and 3rd Floor at max 1.25m centres. 2nd Floor in Scotland at 1.25m centres.

Minimum bearing determined by design
Choose correct full depth hanger for coursework, load, bearing width and desired bearing level.

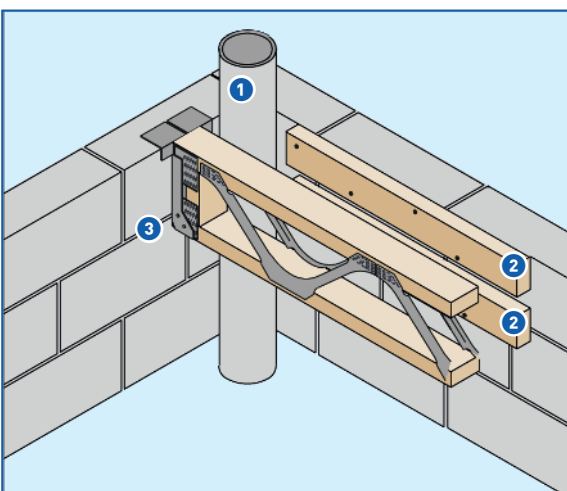

PD03: Fixing round SVP using Bearer Plates

- 1 Soil Vent Pipe (SVP)
- 2 Bearers fixed to wall at floor and ceiling level
- 3 Posi-Joist adjacent to SVP shown in full depth masonry hanger

Note: This detail may not perform well acoustically as sound will be transmitted directly from the floor to the bearer through the inner leaf of the wall.

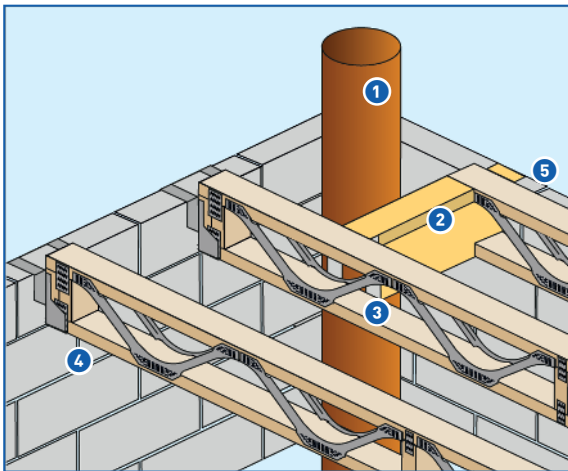

PD04: SVP Opening with Solid Trimmer

- 1 Soil Vent Pipe
- 2 Packer
- 3 Face Fix Joist Hanger (Solid Trimmer to Posi-Joist)
- 4 Joist no more than 6mm from back of hanger
- 5 Solid Trimmer built into wall

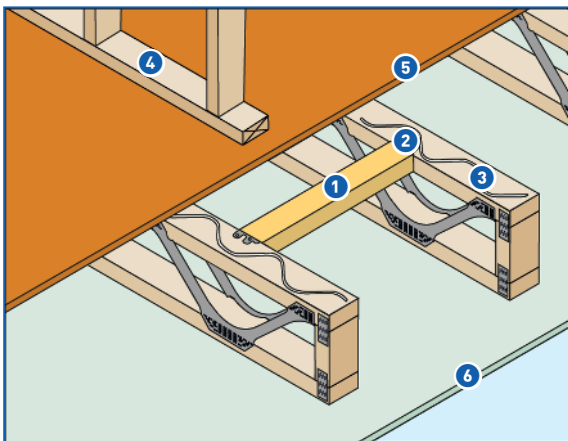

PD05: Non Load Bearing Wall Parallel with Joists

- 1 Noggins at 600mm Centres
- 2 Z-Clip
- 3 Adhesive Bead
- 4 Bottom Rail of stud wall nailed to noggins
- 5 Decking
- 6 Plasterboard

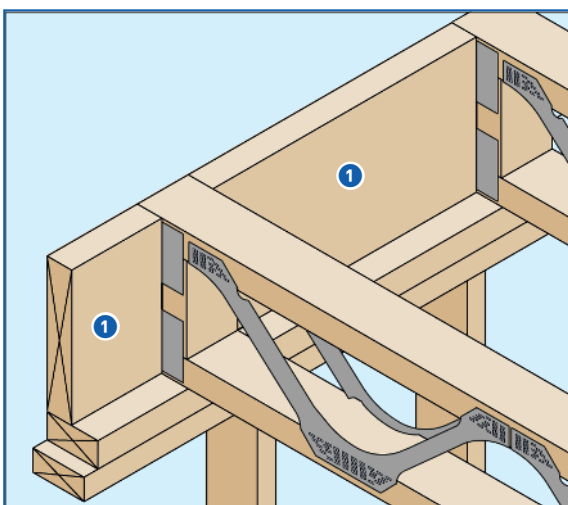

PD06: Bottom Chord Support: Timber Frame with Restraint Blocking

- 1 Full depth chord restraint blocking fixed between Posi-Joists

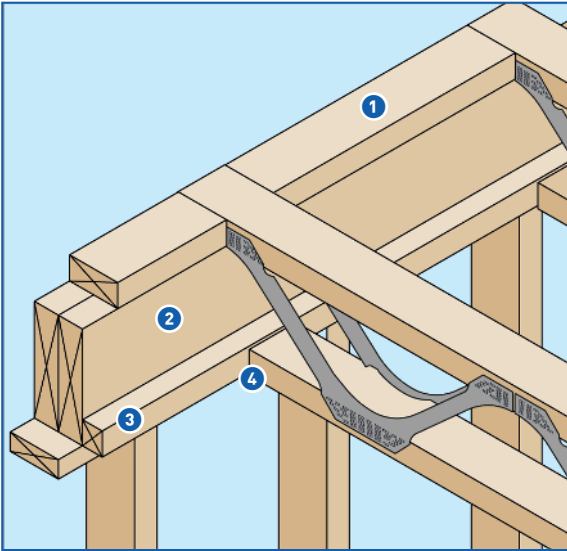

PD07: Top Chord Support: Timber Frame with Ring Beam

- 1 Packing piece to suit Posi-Joist Top Chord flange depth and Ring Beam width
- 2 Timber Ring Beam to suit Posi-Joist depth
- 3 Continuous plasterboard runner
- 4 Gap between end of Posi-Joist Bottom Chord and plasterboard runner

Unless proven by design the Posi-Strut should overhang the bearing by 15mm

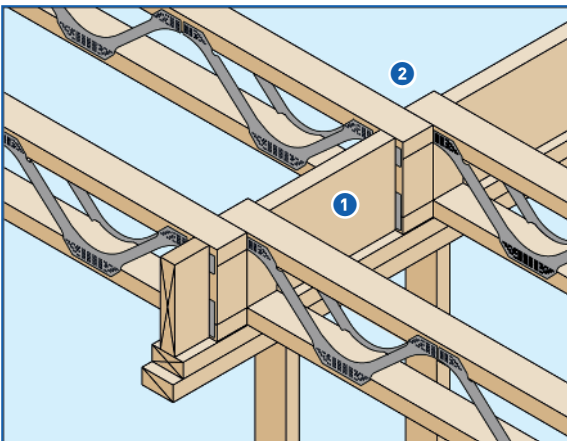
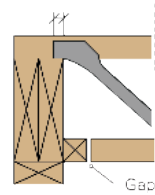

PD08: Bottom Chord Support: Timber Frame Internal (Lapped)

- 1 Single or double full depth blocking fixed between Posi-Joists
- 2 Joists lapped over wall

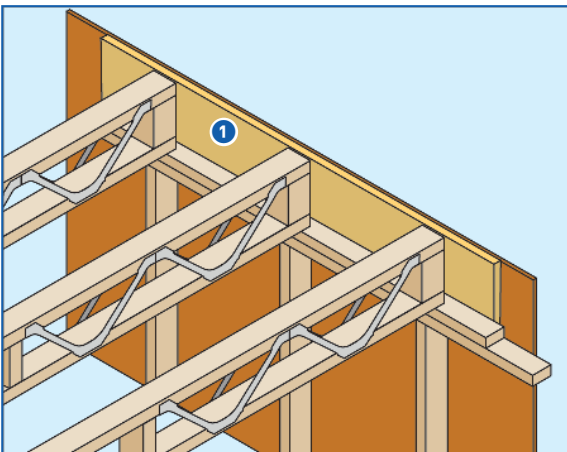

PD09: Bottom Chord Support: Timber Frame with Rimboard

- 1 Solid or EWP Rimboard

Full depth chord restraint blocking fixed between Posi-Joists (omitted for clarity)

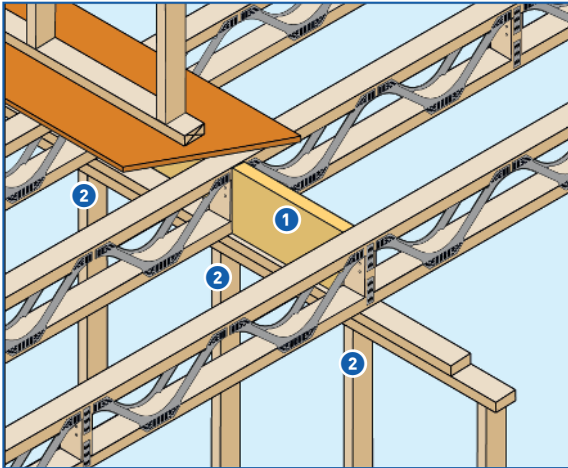

PD10: Intermediate Support Bearing over Stud Wall

- 1 Solid or EWP full depth noggin
- 2 Studs positioned beneath joists

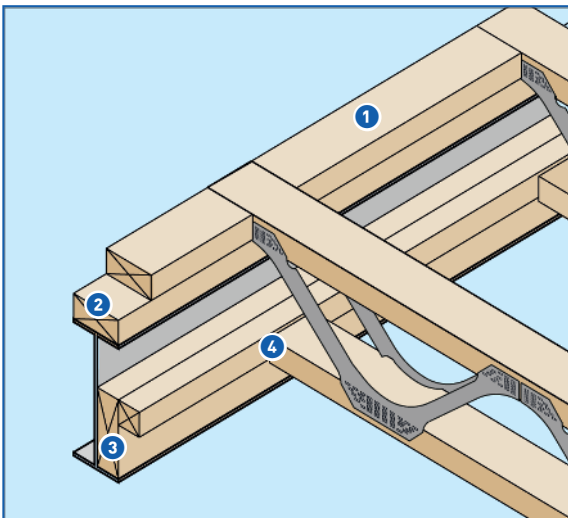

PD11: Top Chord Support: Fixing to Downstand Steel Beam

- 1 Packing piece to suit Posi-Joist Top Chord flange depth and plate width
- 2 Timber plate fixed to top of steel
- 3 Timber pack fixed to beam (size to suit)
- 4 Gap between end of Posi-Joist Bottom Chord and plasterboard runner

Unless proven by design the Posi-Strut should overhang the bearing by 15mm

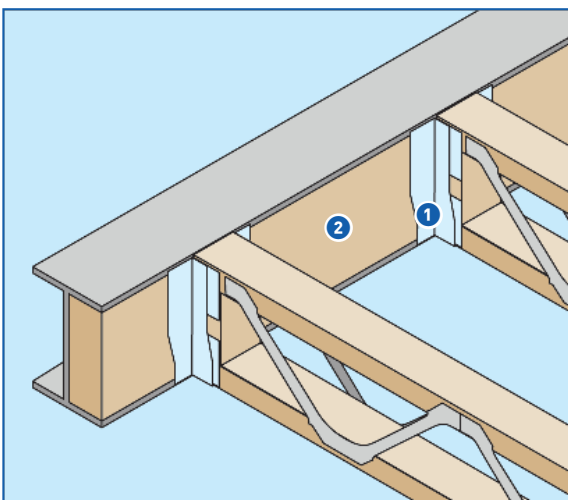
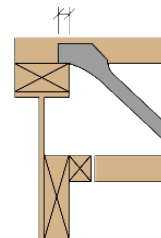

PD12: Bottom Chord Support to Steel Beam

- 1 Face fixed Posi-Joist hanger
- 2 Timber packer as specified by building designer fixed to beam (size to suit)

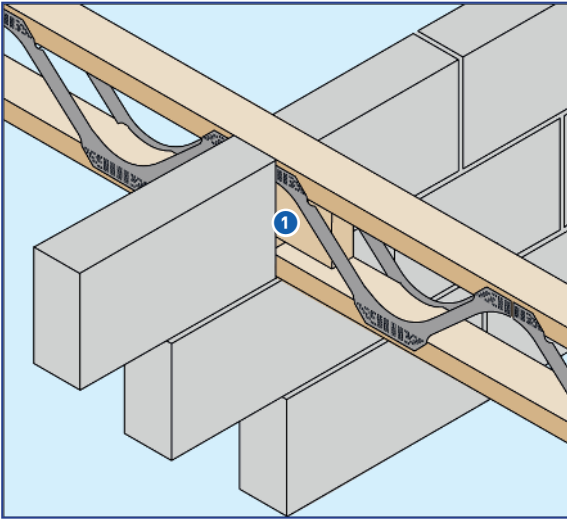

PD13: Bottom Chord Support: Internal Masonry Continuous Joist with solid timber block

- 1 Solid timber block over bearing with grain parallel to span
- Gap to be filled to provide air tightness

Note: Use on internal load bearing walls (not fire walls)

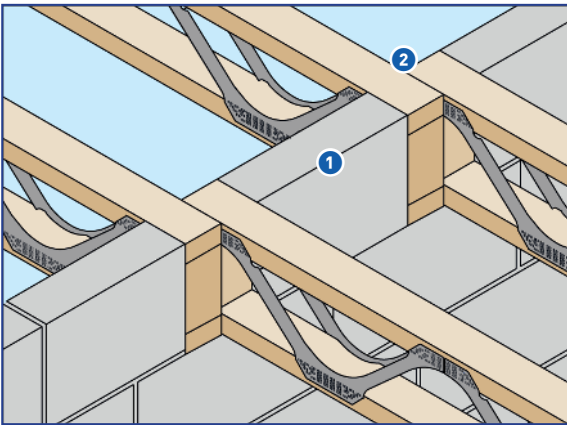

PD14: Bottom Chord Support: Internal Masonry Lapped

- 1 Masonry built up to underside of floor to provide restraint
- 2 Joists lapped over wall

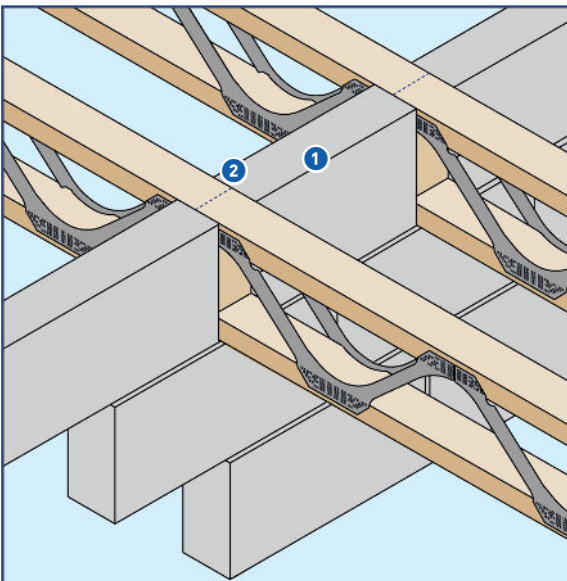

PD15: Bottom Chord Support: Internal Masonry Continuous or Butting Ends

- 1 Masonry built up to underside of floor to provide restraint
- 2 Minimum 45mm bearing required if joist split on centre line of wall

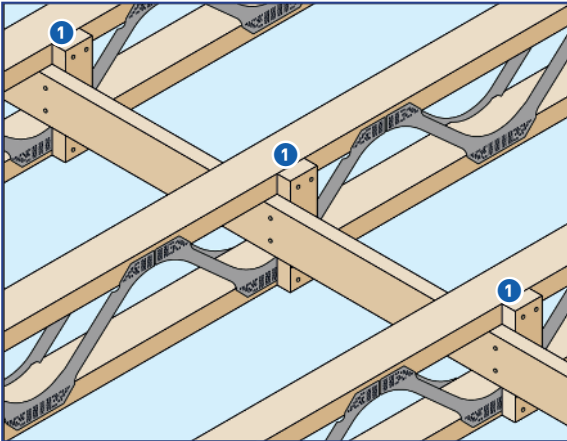

PD16: Strongback Detail (Fixed to Site Added Blocks)

- 1 38x75mm (min) blocks twice nailed to top and bottom members and twice nailed to strongback using 3.1x75mm long galvanised ring shank nails

Note: Strongback size as specified by design

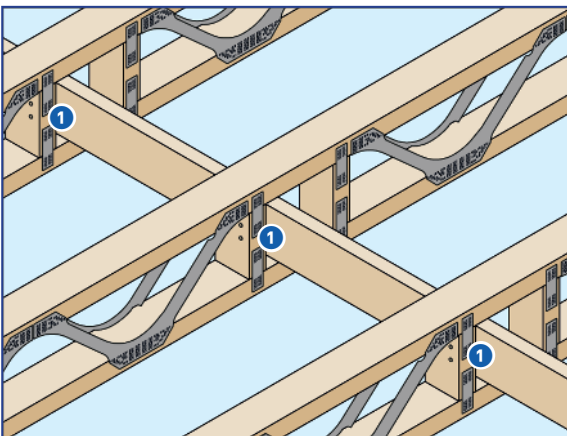

PD17: Strongback Detail (Fixed to Built In Vertical Webs)

- 1 Twice nail strongback to web using 3.1x75mm long galvanised ring shank nails

Note: Strongback size as specified by design

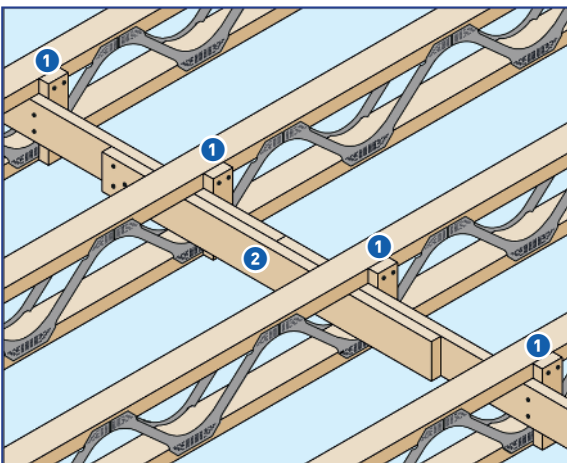

PD18: Strongback splice (Fixed to Site Added Blocks)

- 1 38x75mm (min) blocks twice nailed to top and bottom members and twice nailed to strongback using 3.1x75mm long galvanised ring shank nails
- 2 1200mm long splice fixed with 10no 3.1x75mm galvanised annular ring shank nails each side of splice, nailed through and clenched over on far side

Note: Strongback size as specified by design

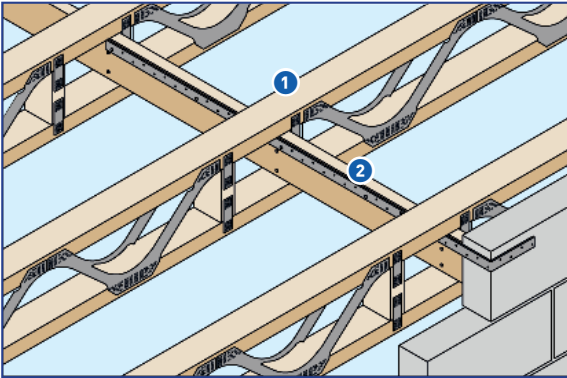

PD19: Horizontal Restraint Strap Fixed to Strongback

- 1 Strongback twice nailed to web using 3.1x75mm long galvanised ring shank nails
- 2 Strap fixed along top edge of strongback. Refer to strap manufacturers details for fixing method

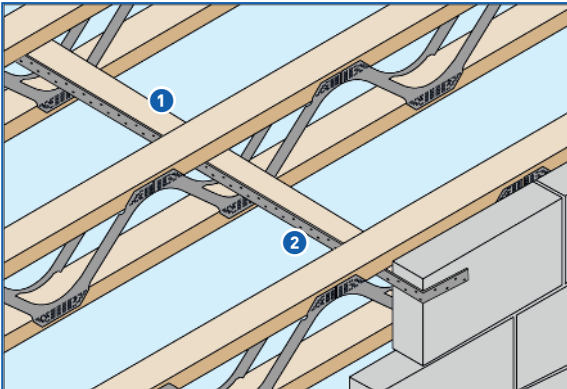

PD20: Horizontal Restraint Strap Fixed to Continuous Noggin

- 1 Min. 35x97 C16 Noggin nailed to underside of top chord of Posi-Joists with 3.1x75mm galvanised annular ring shank nails
- 2 Strap fixed to noggin. Refer to strap manufacturers details for fixing method

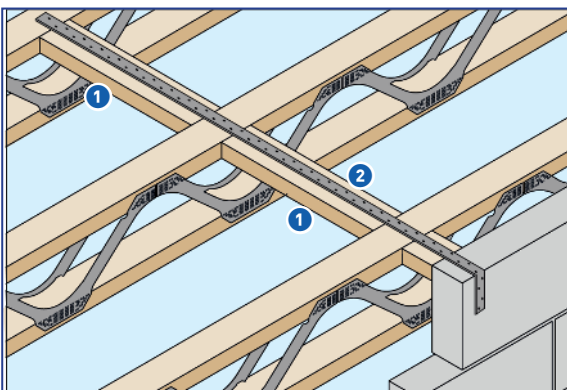

PD21: Horizontal Restraint Strap Fixed to Noggins

- 1 Min. 35x72 C16 Noggin fixed between joists
- 2 Strap fixed to noggins. Refer to strap manufacturers details for fixing method

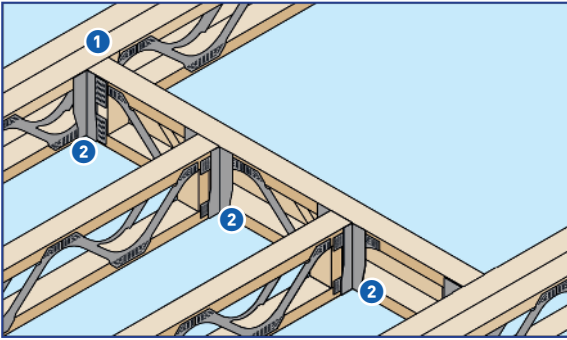

PD22: Opening with 2-Ply Posi-Joist Girder and Posi-Joist Trimmer Beam

- 1 Posi-Joist girder chords fixed together as specified by design
- 2 Face fix Posi-Joist hanger

Do not notch bottom chord of Posi-Joist over bottom flange of hanger

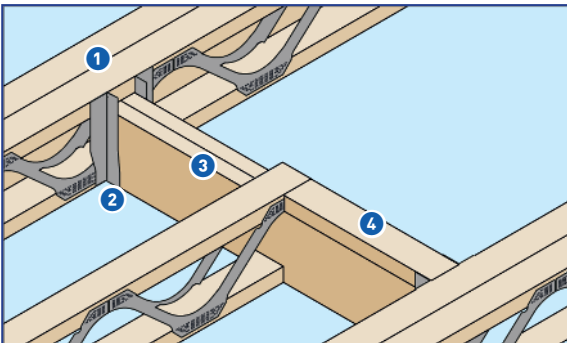

PD23: Opening with 2-Ply Posi-Joist Girder and EWP Trimmer Beam. Top Chord Supported Joists

- 1 Posi-Joist girder chords fixed together as specified by design
- 2 Face fix Posi-Joist hanger
- 3 Solid or EWP Trimmer (Depth to suit)
- 4 Packers to suit Trimmer size

Unless proven by design the Posi-Strut should overhang the bearing by 15mm

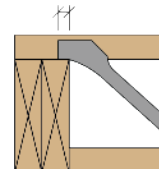

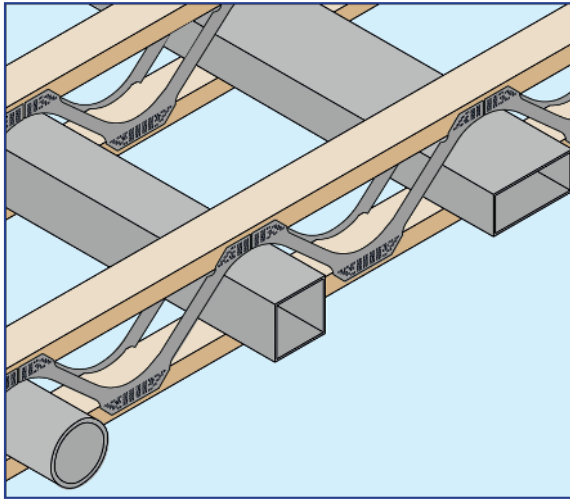

PD24: Maximum Duct Sizes

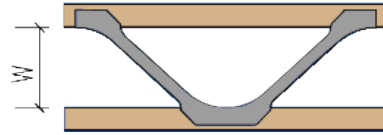

Posi Strut Size	W	Circle Dia	Square	Rectangle Depth											
				50	75	100	125	150	175	200	225	250	275	300	
				Rectangle Width											
PS-8	108	105	95	265	180	90									
PS-9	131	124	115	310	240	180	100								
PS-10	159	150	135	320	270	210	160	80							
PS-12	210	190	155	350	310	260	210	160	110	70					
PS-14	279	250	200	490	440	390	350	300	250	200	160	110	60		
PS-16	327	272	220	510	470	430	390	340	300	260	220	170	130	90	

LARGE SERVICES MAY NEED TO BE OF A FLEXIBLE MATERIAL IN ORDER TO BE FED THROUGH THE VOIDS IN THE POSI-JOISTS

Separating Floor Applications



Floors which separate two dwellings need to meet enhanced requirements for fire resistance and sound resistance when compared to intermediate floors. Consequently the additional materials used to meet these requirements mean that the dead weight of a separating floor will be significantly greater than the dead weight of an intermediate or ground floor.

Fire resistance in separating floors

The period of fire resistance required is at least 60 minutes and this is provided largely by the ceiling plasterboard. The responsibility for the plasterboard specification and fixing rests with the Building Designer.

The following table describes Posi-Joist floors providing 60 minutes or 90 minutes fire resistance to EN1365-2:2014

Fire Resistance	Max Joist Centres	Joist Depths	Ceiling details	Floor deck details
60 minutes	600mm	All depths ≥253mm	2no layers of 15mm Type F plasterboard fixed to joists via resilient bar at 400mm centres (drywall screws at 230mm centres)	18mm OSB/3
60 minutes	600mm	All depths ≥253mm	2 layers of 15mm Type F plasterboard fixed direct to joist soffits (drywall screws at 230mm centres)	18mm OSB/3
90 minutes	400mm	All depths ≥253mm	2no layers of 15mm Type F plasterboard fixed to joists via resilient bar at 400mm centres (drywall screws at 230mm centres)	18mm OSB/3

Sound resistance in separating floors

With the exception of Scotland, separating floors in the UK need to achieve sound resistances of greater than 45dB for airborne sound and less than 62dB for impact sound and this should be demonstrated by pre-completion testing on site, or by adherence to Robust Details.

Robust Details E-FT-3 & E-FT-6 are the tested, proven details for the use of Posi-Joists in separating floors in timber frame construction.

E-FT-3

The E-FT-3 detail comprises of ceiling treatment CT2 made up of two layers of 15mm (nominal 12.5 kg/m²) fireline plasterboard fixed with 25mm and 42mm screws to resilient bars at 400mm centres. On top of an 18mm wood based T&G flooring board, a resilient composite deep batten system with a minimum depth of 70mm is placed with 25mm (10-33kg/m²) insulation placed between the battens. On these battens a 19mm Gypsum based board (nominal 13.5kg/m²) is placed with a final deck of 18mm (min) T&G flooring board on top.

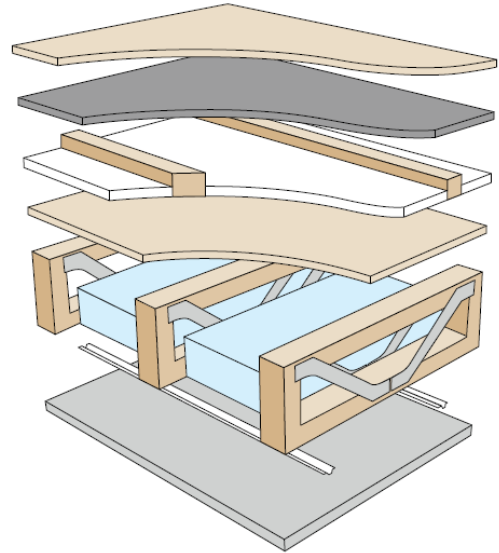

E-FT-6

The E-FT-6 detail comprises of a Collecta® ScreedBoard® 28 Floating floor, on an 18mm thick (min) wood based board, density min 600 kg/ m³. PS10(N) Posi-Joists with 100mm (min) mineral wool quilt insulation (10-36 kg/m³) between joists

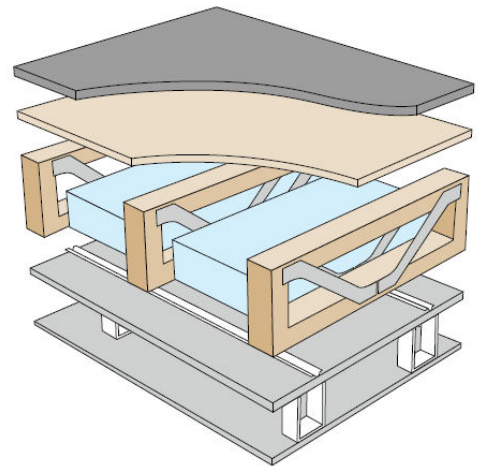

Scotland

Separating floors need to achieve sound resistances of 56 dB for airborne sound and 56 dB for impact sound. These requirements should be demonstrated by pre-completion testing on site.

Republic of Ireland

Separating floors need to achieve sound resistances of 53 dB for airborne sound and 58 dB for impact sound. These requirements should be demonstrated by pre-completion testing on site.

Separating Distance Solutions in Timber Frame construction



Category A, B & C Solutions for Posi-Joist in Timber Frame Construction

The STA 'Design guide to separating distances during construction for timber frame buildings' is intended to assist clients, designers and CDM coordinators consider the risk of fire to neighbouring buildings should a fire occur in a timber frame building under construction.

The guidance principally focusses on separating distances between a receiver (existing building) and the emitter (new timber frame build) and has established how wide these distances can be to mitigate the fire risk through Category A, B and C constructions. Category A is standard timber frame construction, whereas for Categories B and C the timber frame has inherent mitigation measures leading to reduced separation distances.

Posi-Joist FireSafe & FireSafe+ accepted by STA for use in Category C timber frame construction'

Posi-Joist FireSafe floors feature timber members that are treated with an approved FR build flame retardant. Once the Posi-Joist has been pressed in the conventional way, a secondary nailing process is undertaken using approved nails fixed through the outer slots in the Posi-Strut web as illustrated below. The remaining construction including the floor deck are FR treated in accordance with STA approved processes. The nail specification for enhancing the anchorage capacity is an approved gun-fired 3.3x38mm annular ring shank nail.

The FireSafe+ has supplementary 30mm Rockwool RWA45 batt fixed between the webs of the Posi-joist or to one face of the Posi-joist. For full details of floor make up for FireSafe and FireSafe+ please refer to STA Design guide to separating distances during construction for Timber frame buildings. Product Paper 4.

The nails are located in the positions shown below:

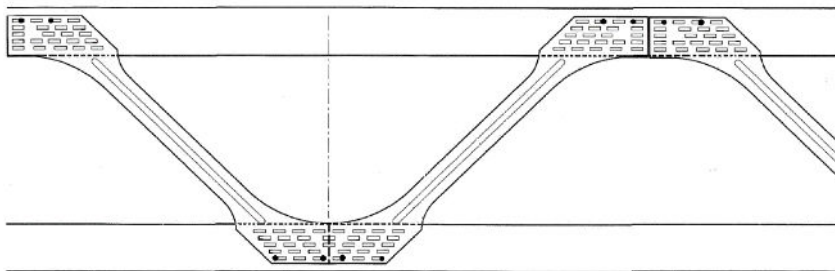

The addition of the supplementary nails will be clearly shown on all Posi-Joist output sheets from PAMIR along with the quantity of nails required.

Nail Reinforcement

Following rigorous tests by TRADA Technology and further tests by MiTek it was established that supplementary nails also enhance the anchorage characteristics of the Posi-Joist webs, often resulting in the reduction of the requirement for double Posi struts. Again the additional supplementary nails will be clearly shown on Posi-Joist output sheets from PAMIR.

Ground Floor Applications

Ground Floor Applications

In ground floor applications there is likely to be no ceiling attached to the underside of the Posi-Joists, meaning the bottom flange will not have any lateral restraint. Therefore multiple spans should either be avoided, or restraint noggins should be inserted at bottom flange level on each side of internal supports where the lower flange is likely to be in compression.

The absence of a ceiling will result in a ground floor feeling less stiff when compared with other floors of the same joist depth and span. As kitchen/utility areas containing appliances that produce dynamic movement (e.g. washing machines) are likely to be located on the ground floor, it is recommended for these areas that more stringent deflection and vibration limits are applied than would normally be the case. This should be discussed with the building designer early in the project cycle in order to control vibration performance. It is also strongly recommended, where possible, locating washing machines and dryers close to end supports of the joists as this will help reduce vibration amplitude.

When planning the arrangement of Posi-Joists for suspended ground floors consideration should be given where practical to making the joists discontinuous between kitchen/utility areas supporting large kitchen appliances and living/dining areas, so as to minimise the occurrence of appliance induced vibration in living areas.

The environment within a suspended ground floor is classified as Service Class 2 and hence the deflection characteristics of the Posi-Joists may be different than for intermediate floors. Provided the void beneath the floor is well ventilated and drained and the ground cover layer inert the floor will perform as expected.

Joists in suspended ground floor applications need particular attention to construction detailing with regard to ground preparation, ventilation, insulation and disabled access.

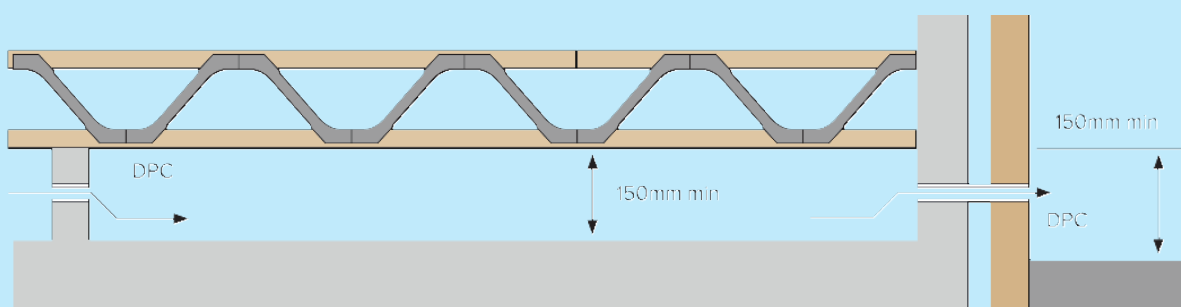

Notes to Diagram

The ground cover layer should be inert and resist the passage of moisture. One of the following constructions may be used, although other options may also be suitable:

- ① 50mm of inert sand, gravel or concrete on 300 micron (1200g) polythene (1000g if PIFA branded) lapped and turned at the edges, on 25mm sand blinding;
- ② 100mm concrete on well consolidated hardcore;
- ③ 50mm concrete on polythene membrane on 50mm sand blinding.

On sites where external ground levels are higher than internal, the internal ground cover should fall to a suitable drainage outlet.

Under floor **ventilation** should be in accordance with The Building Regulations and ventilator manufacturer specifications. Special care should be taken to ensure that adequate cross-ventilation is achieved. A minimum clear height of 150mm should be provided between the underside of the joists and the internal ground cover.

Where protection is required against Radon gas or other ground gases, specialist advice should be sought.

Insulation requirements will vary depending on the floor size and should be calculated by the Building Designer for each floor construction. Insulation can be installed in ground floor constructions by supporting the insulation between the Posi-Joists on either a rigid mesh, a breather membrane, fibreboard fixed between the joists or proprietary insulation suspension systems.

Site Practice & Handling



Site Handling and Storage

Storage on site should be for a limited period of time prior to erection of the Posi-Joists. Posi-Joists should either be stored vertically or on the flat. If stored vertically there should be intermediate bearers at node points not within the bay of a joist, as shown below right. If stored in a flat position, sufficient bearings should be provided to prevent excessive lateral bending.

It is recommend that completed Posi-Joists be strapped together and wrapped in a waterproof protective covering to protect them from short term exposure to inclement weather.

Special precautions should be taken when stacking top chord supported floor cassettes to prevent the stack lozenging in storage. Additional bracing to the ends of the stack should be fixed to stop lateral movement.

Care should be taken when handling the Posi-Joists to avoid bending, twisting or dropping.

When loading/offloading with a crane, slings should always be attached to the timber chords or the cassette lifting points, and not to the metal webs to avoid buckling. Slings should be attached at panel points closest to the quarter points of the Posi- Joists as shown right.

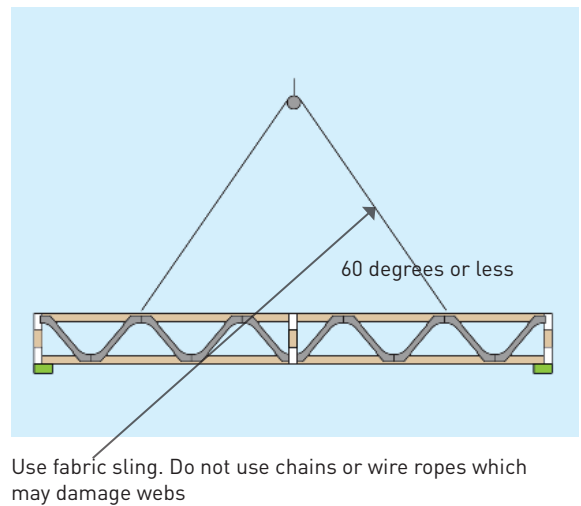
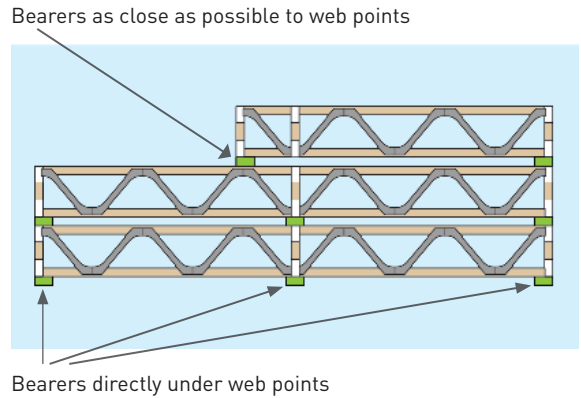

Set Out and Placement

Posi-Joists are generally placed perpendicular to the load bearing supporting walls and should be located so that the distance between them does not exceed the design spacing – always consult the Posi-Joist layout drawing and proceed with erection of the floors as follows:

- 1 Plan the erection sequence and place the Posi-Joists close to where they are required, only distribute a sufficient number of joists around the building which can be erected in a reasonable period of time. Posi-Joists should be protected from inclement weather and stored as noted above.
- 2 Before lifting the Posi-Joists to scaffold level do make sure the correct end of the joist is at the appropriate support as the end details may be different. Also be aware of any internal supports which are being used and that the special internal bearing detail for the joist is in the correct position.
- 3 If the Posi-Joists are supported over more than 2 supports make sure all the supports are the same level and when the joists are lifted into place they rest on all of the supports.
- 4 If the Posi-Joists are supported on masonry hangers, make sure they are the ones specified and are firmly anchored in place and that the masonry is cured in line with hanger requirements. Joists should have a full bearing with no more than a 5mm gap between the end of the joist and the face of the hanger. Masonry hangers with a cavity return and integral strap provide lateral restraint to wall heads.
- 5 Make sure the Posi-Joists are erected the correct way around, the joists will normally be marked "TOP" and the first metal web will normally start at the top of the Posi-Joists
- 6 The Posi-Joists are positioned to coincide with the deck joints, the first of which is normally 1210mm away from the wall face in masonry construction or 1200mm from the cavity face in Timber Frame construction when the deck extends to the cavity face; when the joists are spaced at 400 or 600mm centres. There is normally a 10mm perimeter gap between the face of the deck and the face of the wall in masonry construction to allow for potential expansion of the deck. The board material is normally 1200 x 2400mm, the long dimension spanning at 90° to the joist span. The remaining joists are normally spaced on a grid of 400, or 600mm centres, on occasion at 480mm centres.
- 7 When the deck is set out from the face of the wall it is normal to have the first joist edge 50mm from the face of the wall where in Timber Frame construction with the deck set out from the cavity face it is normal to not have a joist close to a wall, the deck and plasterboard being supported on a timber ledger nailed to the frame. Carefully follow the layout drawing and the wall/joist interface details provided by the Building Designer, in particular in Timber Frame where the joist centres and the stud centres may have to line through.
- 8 The penultimate Posi-Joist in the run is set out on the standard module and the last joist is positioned similar to the first in the run.

- 9 Posi-Joist stair trimmer joists and trimmers will be required around stair openings which may be on the main joist grid or usually off the grid. Set these joists out strictly in accordance with the architectural and Posi-Joist layout drawing and fix the trimmer joist to the stair trimmer and the trimmed joists to the trimmer joist with the metal hangers specified making sure that any 2 ply joists are adequately connected together as detailed.

- 10 To temporary brace and space the Posi-Joists which have been laid in position fix a piece of 22 x 97 bracing to the top of the joists at their ends and mid span or around 2.4m centres on spans longer than 4.8m.

- 11 Install the strongback bracing as detailed, the strongback is always installed on edge not on flat and must be fixed to the integral strongback blocks or noggin pieces nailed to the face of the joist. The strongback must be fixed tight to the underside of the top chord. On all top supported Posi-Joist floors with installed strongbacks it will not normally be necessary to use any temporary diagonal bracing. On bottom supported wide flange chords (72mm or wider) once the strongback and rim boards are fixed in place no temporary diagonal bracing is normally required. On bottom supported narrow chords (35 - 47mm) then temporary diagonal bracing is required as well as the strongback and rimboard bracing.

- 12 When all the Posi-Joists have been positioned and fixed in place, the partition noggins, perimeter noggins, rim boards, when required can be installed, and in the case of masonry construction the steel lateral restraint straps should be fixed in place at no greater than 2m centres and should extend over 3 joists.

- 13 The floor carcass is now ready to receive the decking material and acoustic material where required.

- 14 The maximum load of sheet materials temporary stored on the Posi-Joists is 250kg/m² and should not be greater than 300mm deep. This equates to 16 sheets of 18mm chipboard, 13 sheets of 22mm chipboard or 20 sheets of 15mm plasterboard.
 Where the sheets are stacked by hand they should span lengthways across the joists, (Fig 1), when lifted mechanically they should be seated on 5 bearers the width of which are 600mm longer than the width of the board. (Figs 2 & 3).

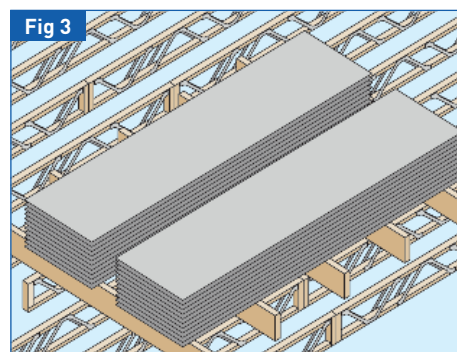
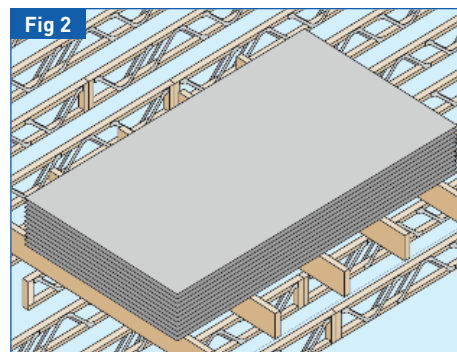
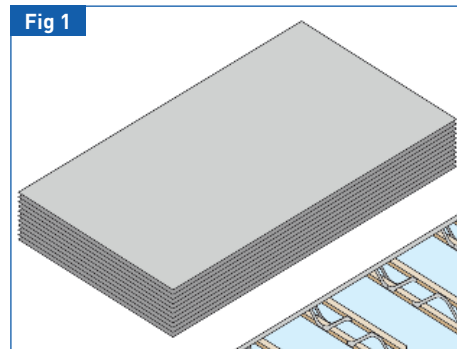

Set Out and Placement

This diagram indicates temporary erection bracing only. It is applicable to both masonry and timber frame construction. It does not apply to top hung Posi-Joists in timber frame construction which do not require temporary bracing (See PD09)

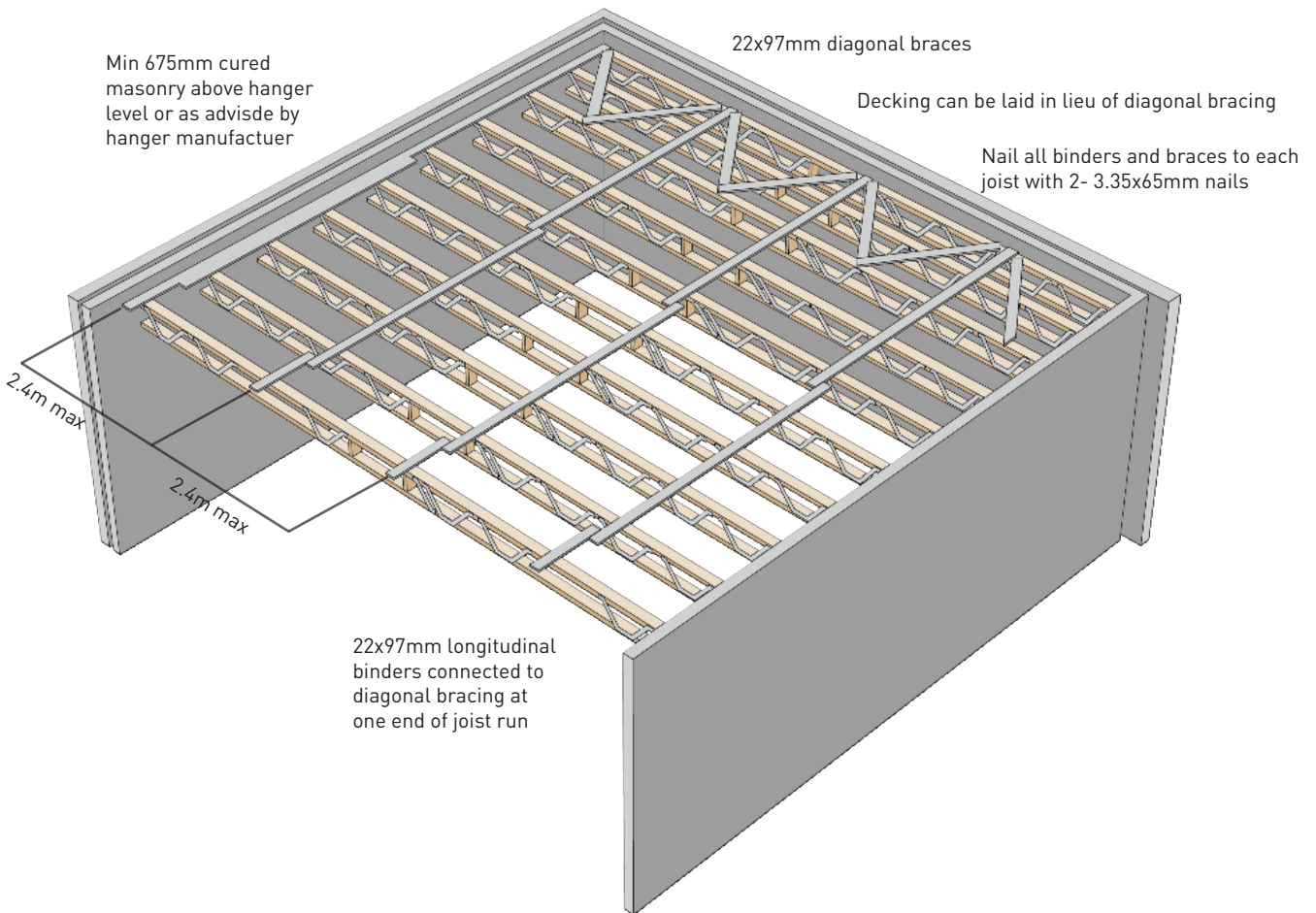

Temporary Erection Bracing Notes

The builder is responsible for identifying and minimising the risks involved in erecting Posi-Joists to ensure that the health and safety of all workers is maintained. Builders should be aware of the health and safety responsibilities imposed on them by the Construction (Design and Management) Regulations 1994. Proper erection procedures and bracing are vital to the safe construction of Posi-Joist floors. The notes on the following page may assist builders in preparing a safety assessment.

Temporary Erection Bracing Notes (continued)

- 1 Un-braced Posi-Joists may be unstable.
- 2 Do not allow anyone to walk on un-braced Posi-Joists.
- 3 Do not store building materials on un-braced Posi-Joists.
- 4 Posi-Joists should be erected straight and vertical. The maximum deviation from horizontal should not exceed 10mm and the maximum deviation from vertical should not exceed 2mm.
- 5 Temporary bracing comprises diagonal bracing, longitudinal binders and permanent strong-backs.
- 6 All longitudinal binders, diagonal braces, strong-backs and hangers should be completely installed and fully nailed as detailed.
- 7 Lateral strength should be provided by a diagonally braced system across at least 3 Posi-Joists as shown in the Erection Bracing diagram. Additional braced and blocked systems should be added at 12m spacing in long joist runs.
- 8 Construction materials may only be stored on joists when all bracing is in place and the material should be spread over at least 4 joists and not more than 1.5m from a support. Floor/ ceiling boards may be stacked up to 250mm high (150kg per joist at 600mm centres, 100 kg per joist at 400mm centres) on braced floors.
- 9 Flooring should be fully fixed to the Posi-Joists before additional loads are placed on the floor.
- 10 Temporary bracing may be progressively removed as decking is fixed.

Dos and Don'ts

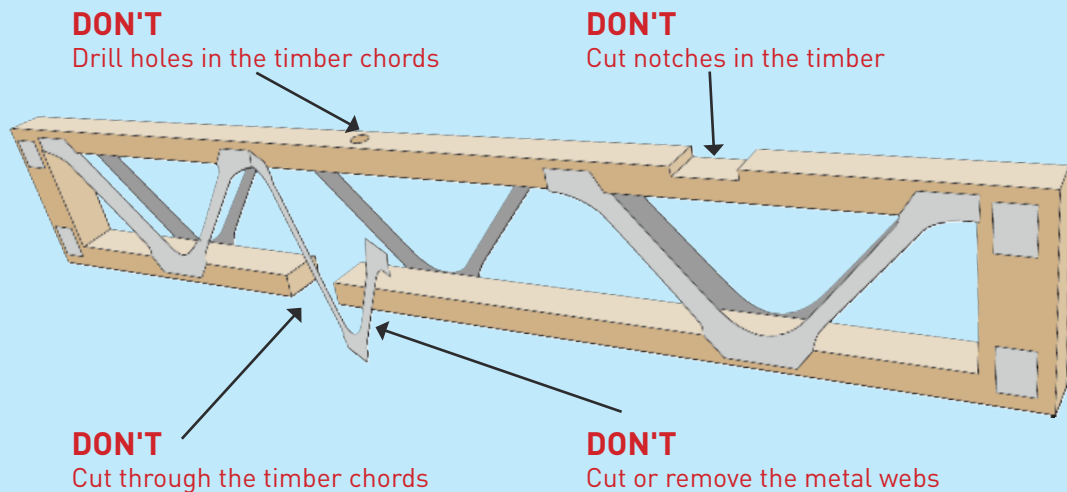

Do

- ✓ Store as shown in handling and storage section
- ✓ Lift the Posi-Joists in a vertical position
- ✓ Use the open web feature for services
- ✓ Protect the Posi-Joists from inclement weather

Roof Applications



Posi-Rafters

Posi-Strut webs are increasingly being incorporated into roof structures to take advantage of the many benefits on offer.

Posi-Rafters are parallel chord trusses, plated together with Posi-Strut metal webs. As with Posi-Joist floor joists they are designed and manufactured offsite and tailored to the requirements of each individual project. They arrive made to measure and accompanied by full layout drawings for speed of erection.

Posi-Rafters are suitable for both pitched roofs and flat roofs. They are stronger than solid timber rafters and so can span further and require less internal support.



A wide range of depths and end details provide great flexibility in their application, and the need for expensive hangers and metalwork can be eliminated through clever detailing and connections. The open web construction allows for services and utilities to be easily routed through the rafters with no need for cutting or drilling or battening out.

Posi-Rafters can also offer greater thermal U values than solid timber rafters.

Posi-Rafter Details

A variety of end details can be incorporated into a Posi-Rafter to suit different support conditions.

RD01: Upstand wallplate support via plated block

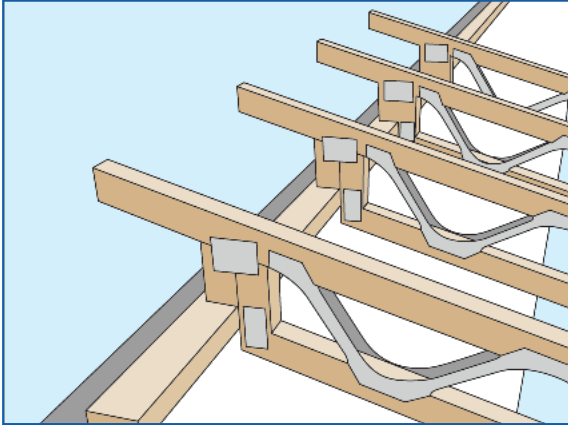

RD04: Typical ridge detail on Steel Beam

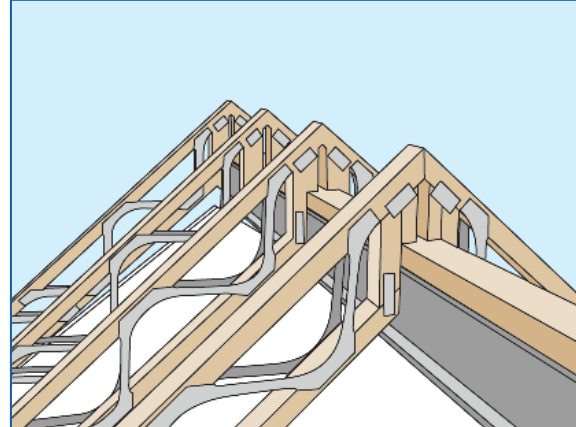

RD02: Wallplate support via plated block

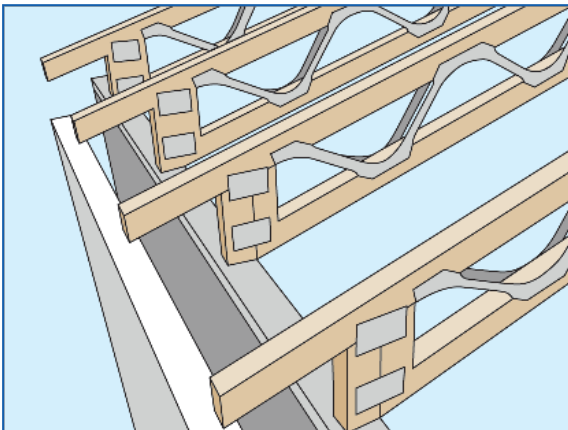

RD05: Solid Trimmers installed perpendicular to roof slope allows face fix hangers to trim openings

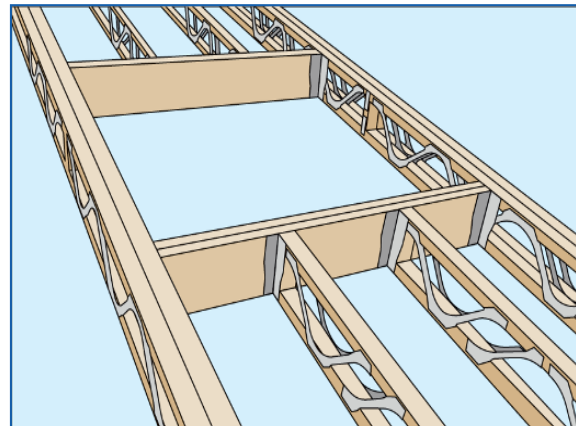

RD03: Pre-Cut Chamfered Bottom Chord to avoid notching wallplate

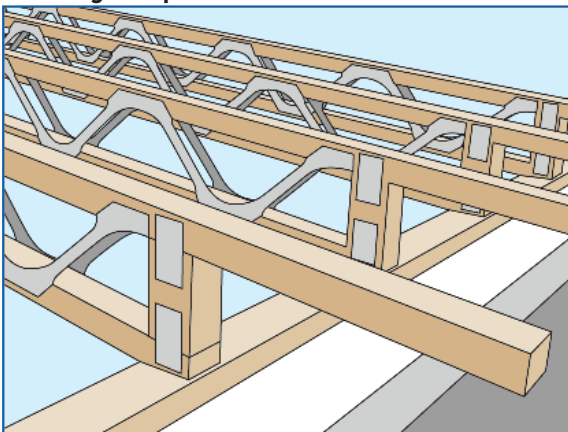

Posi-Attics

Posi-Attic trusses combine the solid feel of a Posi-Joist with the benefits of a conventional attic truss. The strength of the Posi-Joist floor provides greater room widths, for increased living space within the attic, delivering maximum value to the client.

The Posi-Joist floor is ideal for the installation and maintenance of Heat Recovery Ventilation Systems, soil pipes and the increasingly diverse range of services installed in modern homes.



Wall Applications



Posi-Stud

Though not commonly used, on occasion when a construction project requires an over-height wall panel, Posi-Studs have provided the ideal solution.

The combination of the different available timber sections and the different Posi-Stud web sizes mean that a wide range of different wall widths can be achieved using this system. In this final section of the World of Posi Technology we provide you with indicative information regarding the thermal performance that Posi-Studs can achieve and indicative construction details for the use of Posi-Studs in wall construction.



Sample Construction Details

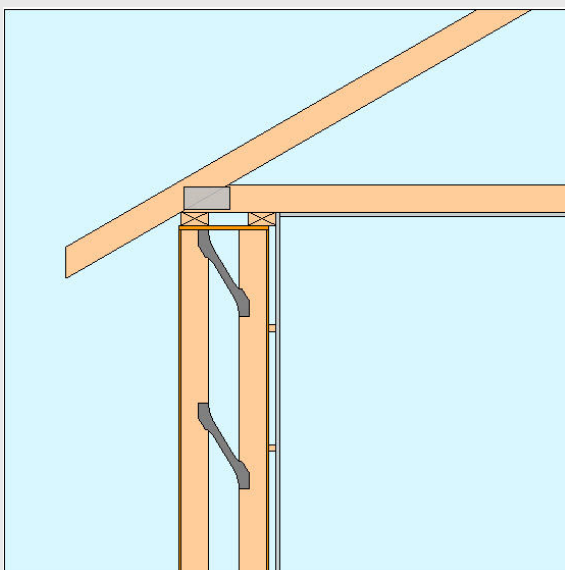

Sample wall to roof connection detail

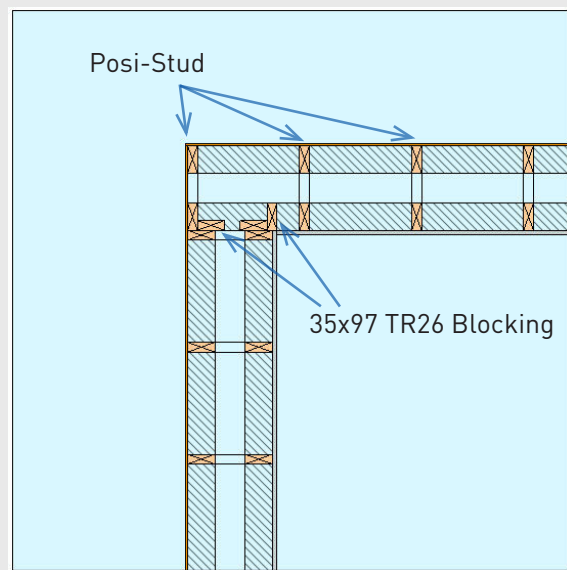

Sample exterior connection detail

Thermal Performance

300mm Posi-Stud

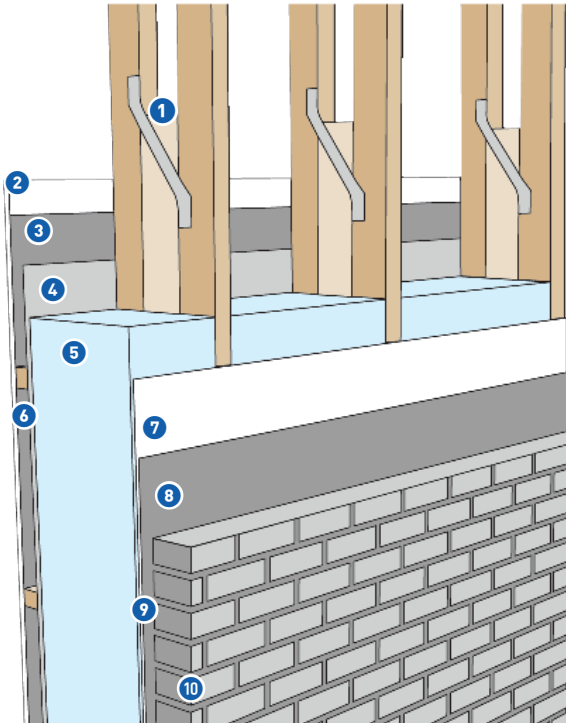

- 1 Posi-Stud filled with mineral wool
- 2 Inner lining of plasterboard
- 3 Vapour control layer
- 4 OSB Sheathing
- 5 2 No. 150mm layers of 0.035 Lambda λ (W/mK) mineral wool
- 6 Battened service zone
- 7 OSB Sheathing
- 8 High Performance Breather Membrane
- 9 Drained and vented 50mm cavity
- 10 Outer leaf of masonry

Calculated U-Value: 0.12 W/m²K

200mm Posi-Stud

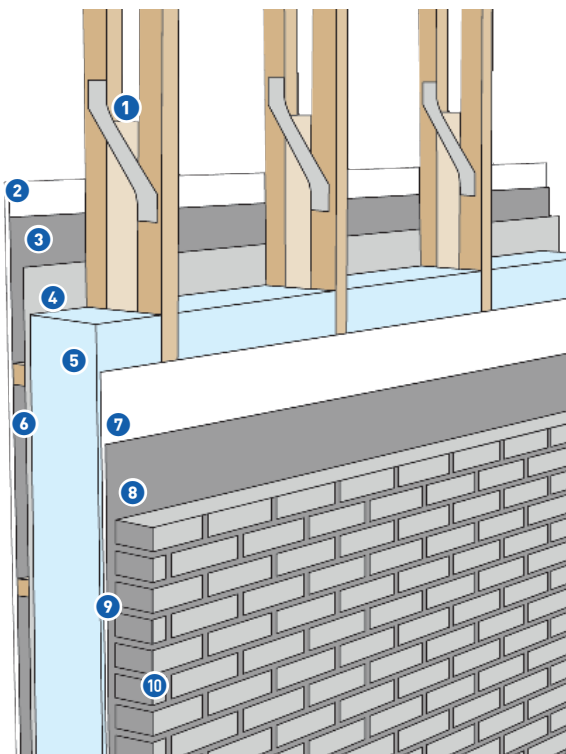

- 1 Posi-Stud filled with mineral wool
- 2 Inner lining of plasterboard
- 3 Vapour control layer
- 4 OSB Sheathing
- 5 2 No. 100mm layers of 0.035 lambda λ (W/mK) mineral wool
- 6 Battened service zone
- 7 OSB Sheathing
- 8 High Performance Breather Membrane
- 9 Drained and vented 50mm cavity
- 10 Outer leaf of masonry

Calculated U-Value: 0.17 W/m²K

MiTek[®]



MiTek Industries Ltd

MiTek House, Grazebrook Industrial Park, Peartree Lane, Dudley, DY2 0XW

Tel: +44 (0) 1384 451400 Email: info@mitek.co.uk

www.mitek.co.uk