



The Buyers' Guide to:
Metal Web



Introduction

High performing floors are what contractors look to achieve for their house buying customers. These ideals can be brought a step closer by using correctly designed and installed metal web joists.

These products are parallel chord trusses made from strength-graded timber, joined with engineered steel webs. Popular with architects, specifiers, homebuilders and contractors, factory-made metal web joists are lightweight, strong and versatile. This combination allows longer clear spans giving designers greater freedom of room layout.

Frequently used in the construction of floors but also used in roofs, metal web joists are easier, faster to install and more cost-effective than other flooring solutions. The main benefit is the easy access they provide for services, with no need to cut or drill holes in the joist. Pipework, ducting and cabling for heating, ventilation or electrics can easily be routed through the joist space long after the metal web joists have been installed.



Images courtesy of Wolf Systems Limited, MiTek Industries, ITW Construction Products, Pasquill and Simpson Strong-Tie

Contents

00. Introduction	01
01. Metal web joists	02
02. How to buy metal web joists	03
03. Responsibilities in metal web joist floor design	04
04. Glossary of terms	06
05. Design considerations	08
06. Essential metalwork for floor systems	14
07. Site handling, storage and installation	15
08. Do's and don'ts	17
09. Construction checklist	18

1 Metal web joists

Metal web joists and beams are structural building components which can be used to create a variety of floor, roof and wall constructions. They can be combined with solid and engineered wood products or structural steel, either on site to provide complete floor and roof elements or through offsite manufacturing to deliver fully assembled floor or roof cassettes.

Metal web joists can be used beyond domestic applications and are also suitable for use in commercial and industrial buildings constructed from timber frame, masonry, steel or concrete.

Benefits

The benefits of metal web joists are:

- The open web structure means metal web joists are lighter to handle than timber equivalents
- Wide timber chords allow for easy fixings for both the floor decking and ceiling finish meaning quick and easy installation
- Flexibility of design and use of high strength materials mean longer spans
- Open web design delivers ease of access for services
- Long-term stability is achieved through less shrinkage due to the reduced section of timber
- Increased spans, simpler installation of utilities and services, flexibility of design and faster installation results in significantly reduced build costs
- Made to measure products virtually eliminate site wastage
- Consistent quality thanks to precision engineering and offsite manufacture.

Trussed Rafter Association (TRA) members create bespoke designs for all types of homebuilders, from major volume housebuilders to individual self

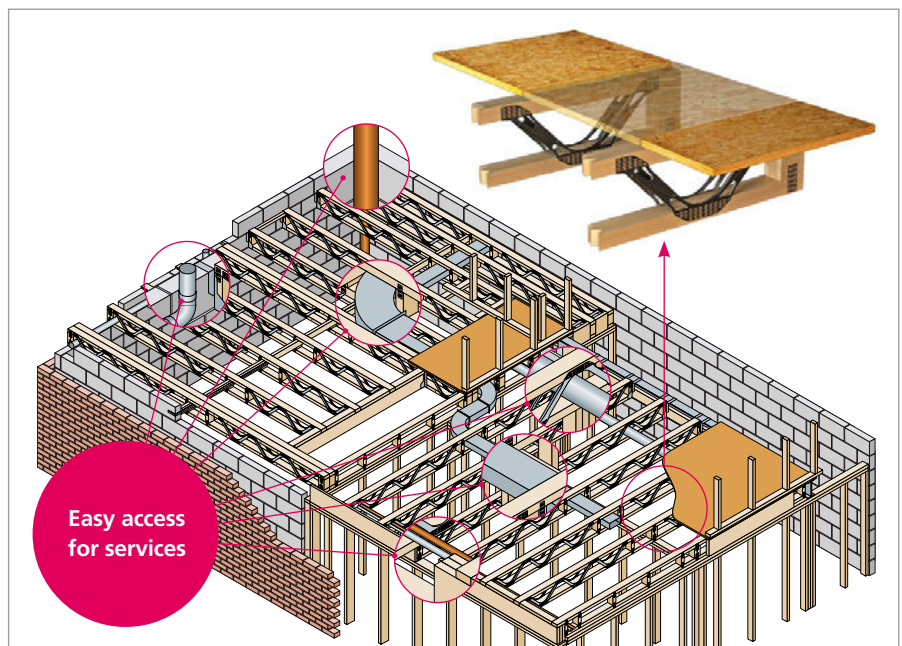

and custom builders and community self-build projects. Many members can also help with supply and fit, or supply, fit and finish services according to your needs and budget.

TRA members specialise in commercial metal web joists for hospitals, supermarkets, schools and other large public projects, all designed to Eurocode 5 for good practice structural integrity. Many TRA metal web joist manufacturers also manufacture trussed rafters, which can offer the opportunity for cost savings through streamlining the supply chain. We've produced this buyer's guide to outline where metal web joists can be used and to highlight the key considerations when choosing metal web joists for your project.

About the TRA

The TRA is the respected voice of the trussed rafter and metal web joist industry in the UK and Ireland. We are committed to stringent standards of quality and service and set a professional benchmark for the industry.

Members include the principal manufacturers of trussed rafters, metal web joists, suppliers and professionals involved in roof and floor design and construction.

The TRA requires all its manufacturing members to have third-party supervised quality assurance and professional indemnity insurance, helping to ensure quality and peace of mind for the customer.



To find out more, please visit the website www.tra.org.uk to find a TRA member near you who will be happy to advise you on next steps.

2 How to buy metal web joists

When you buy metal web joists from a TRA member, you can be confident your supplier has been vetted and approved by the industry's leading professional association.

We advise that you always speak to a TRA member to talk about your specific needs as early as possible in the project. They will be happy to discuss your requirements and to advise on the best approach for your project.

TRA members offer a range of services to suit your requirements. These are categorised as follows and you can choose the service(s) according to your project needs:

- Design and supply
- Design, supply and fit
- Design, construct and supply.



Design and supply

In most cases metal web joists are provided on a design and supply basis, with the metal web joist manufacturer also taking on some or all the elements of the floor design. This service involves the customer supplying detailed project information directly to the TRA member, who then designs the metal web joists using specialist software. Such project drawings will need to include the information listed in the 'Examples of key design responsibilities' section of this guide. When the metal web floor design is completed, a copy will be provided to the customer for approval and once signed off, the TRA member will manufacture the components to your specification and supply them to your site, at an agreed date and time.

When choosing a design and supply service, the customer is responsible for ensuring safe unloading and correct storage of the products when they are delivered. The customer is also responsible for ensuring that the metal web joists are properly installed by a suitably qualified person.



Design, supply and fit

Where required some TRA members can also provide a service that includes the manufacture, delivery and installation of metal web joists. With a supply and fit service, you have just one point of contact throughout your floor construction. Choosing this option gives you the peace of mind in knowing that those responsible for the installation are fully qualified specialist floor installers. In addition, the responsibility for developing risk assessments and safe systems of work for storage and installation lies with your chosen TRA member.



Design, construct and supply

As we see increasing demand for offsite manufacture, many TRA members are offering the customer the opportunity to have metal web joists constructed in the factory and delivered to site as pre-assembled floor units, termed cassettes. Being offsite manufactured, floor cassettes help reduce construction time and labour required on-site. Improving build schedules and in many cases potentially enhancing build quality.

To help meet the responsibilities set out here, detailed drawings and written instructions are always provided by TRA members as part of the floor delivery package. In addition to this specific technical information, TRA members can also provide guidance on the transport, handling, storage and installation of our products. Therefore, contractors and designers should always work closely from as early a stage as possible with their chosen TRA member.

3 Responsibilities in metal web joist floor design

All TRA members use the latest software to design metal web joist floors to comply with BS EN 1995-1-1 (Eurocode 5) and manufacture them in accordance with European Technical Assessment Document ETAD 011 for light composite wood-based beams and columns.

The role of the building designer and the metal web joist floor designer

The building designer, usually the architect or structural engineer, has overall responsibility for the design and structural integrity of the building. Part of this responsibility is to ensure that individual components within a building act together to form an integrated structure. They should ensure that the floor design is compatible with the supporting structure and that the floor is adequately connected to the walls.

Information sharing is the key to the process and the guide below is a brief summary to how the responsibilities are shared:



Building Designer

Main responsibilities:

- Lateral restraint of walls via the floor

Shall provide the following information to the floor designer:

1. The building footprint and layout
2. The joist span, direction and floor depth available
3. Design dead load or details of types and weights of floor and ceiling coverings
4. Intended building use and design-imposed loads
5. Position and weight of non-load bearing internal partitions
6. Other additional loads such as hoist tracks
7. The positions and method of support at all bearing positions e.g. hangers or built-in
8. Any special requirements for floor members e.g. specific chord widths, joist spacing or deflection requirements
9. Size and location of required floor openings e.g. stairs
10. Size and location of large or non-standard services planned to be run through the floor zone.

Metal Web Joist Floor Designer

Main responsibilities:

- Safe support of all floor design loads
- Ensure loads adequately transferred to the building structure
- Design of fixings between metal web joists and timber beams within the floor zone

Shall provide the following information to the building designer:

1. The size and specification of metal web joists
2. Positions, direction and spacing of all floor components
3. Location of all support bearings used in the design
4. The loadings and use conditions for which the metal web joists have been designed
5. The basis for the design and range of reactions at support positions
6. Maximum deflection limits and other performance criteria
7. Specification of strongbacks or other stiffening elements required
8. Fixing details for all multiple members and joist to joist or joist to timber beam connections
9. Design of joist to masonry or beam to masonry connections required
10. Any special handling, storage or installation requirements.

The building designer should provide the metal web joist manufacturer with all relevant information (as detailed on page 4). The manufacturer provides the materials to produce a floor that meets the criteria specified by the building designer.

The role of floor designer may be allocated by the building designer to an independent consultant or engineer and in such cases the metal web joist manufacturer will simply supply the components specified.

In addition to this specified design process, NHBC standards set out that design and specification information should be issued by the metal web joist designer to site supervisors, relevant specialist subcontractors and suppliers as below:

- Direction of floor span, and size and spacing of joists
- Size of trimmers and trimming joists
- Position of strutting
- Detailing of openings in the floor
- Supporting walls below
- Walls and partitions above
- Positions of restraint straps
- Positions of large service penetrations e.g. chimneys, SVPs
- Position of insulation
- Details of all junctions
- Manufacturers' recommendations for assembly and fixing of proprietary components.

Advice and guidance

To help meet the responsibilities as set out on page 4, detailed drawings and written instructions are always provided by TRA members as part of the metal web joist delivery package. In addition to this specific technical information, TRA members can also provide guidance on the transport, handling, storage and installation of products. Therefore, contractors and designers should always work as closely as possible from an early stage with their chosen TRA member.



4 Glossary of terms

Bearing

The part of a metal web joist receiving structural support. This is usually a wall but can be a beam or post etc.

Building Designer

The person responsible for the structural stability and integrity of the building as a whole.

Cassette

Factory controlled, pre-assembled floor unit that helps reduce labour and construction time on-site.

Chord

The top or bottom structural timber element of a metal web joist.

Chord Splice

A structural joint in the top or bottom chord formed using a connector plate.

Clear Span

Distance between bearing points at each end of the metal web joist.

Connector Plate

Metal plate having integral teeth punched from the plate material. It is used for joining timber in one plane with no overlap. It will have an accreditation certificate and will be manufactured, usually, from galvanised steel.

Dead Load

The load produced by the fabric of the building, always long-term (see design loads).

Deflection

The deformation caused by the loads.

Imposed Load

The load produced by occupancy and use including storage, inhabitants, moveable partitions. Can be long, medium or short term.

Intermediate Support

Additional bearing point within the length of the metal web joist.

Live Load

Term sometimes used for imposed loads.

Metal Web Joist

Parallel chord trusses made from strength-graded timber, joined with engineered steel webs.

Metal Webs

V shaped metal plates having integral teeth punched to a patent design from the plate material. They are applied to both sides of a metal web joist to separate and support the top and bottom chords. Each web will have an accreditation certificate and will be manufactured, usually, from galvanised steel.

Metal Web Brands

There are currently three brands of metal web joists available through TRA member manufacturers. The general information in this guide is applicable to all brands of metal web joist:

- easi-joist by Wolf Systems Limited
- Posi Joist by MiTek Industries
- SpaceJoist from ITW Construction Products.

Nogging

Timber pieces fitted at right angles between the metal web joists to form fixing points.

Overall Span

Total length of the metal web joist.

Restraint Strap

Metal component designed to tie joist and walls for restraint purposes.

Strongback

A strongback is used to dampen vibration by increasing the stiffness of the floor and reduce deflection by load sharing.

Timber stress grading

The classification of timber into different structural qualities based on strength.

Trimmer

Additional metal web joists or pieces of timber used to frame around openings.

Joist Definitions

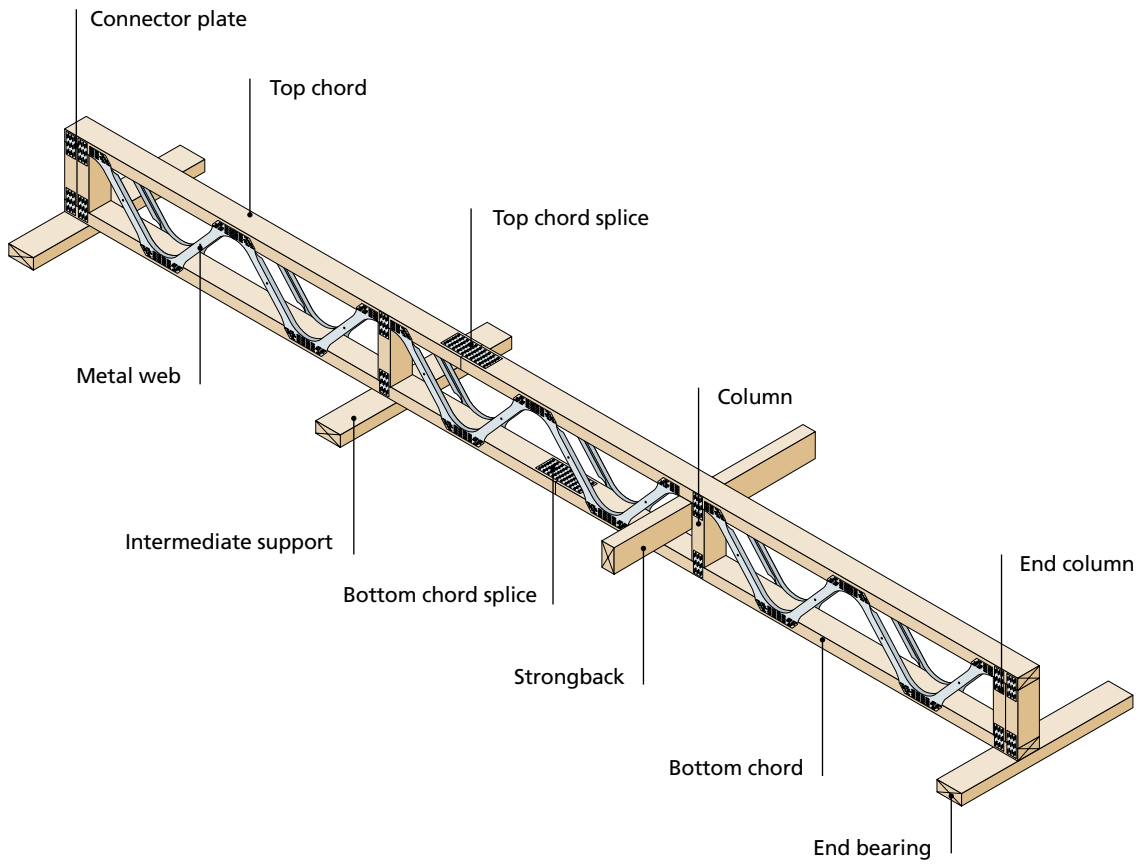

Floor Definitions

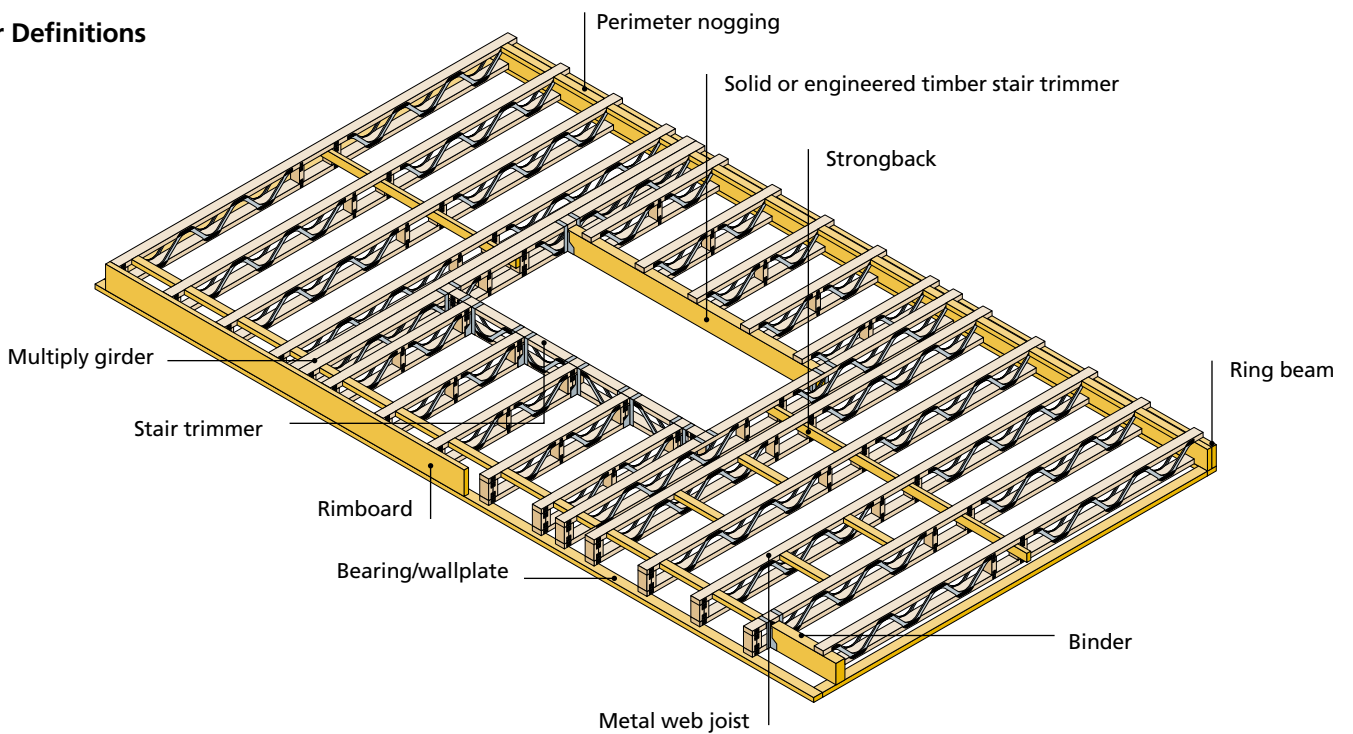

5 Design Considerations

As set out in **section 3 Responsibilities in metal web joist floor design**, the building designer needs to provide the metal web floor designer with a set of information on which the floor design will be based. A consideration of these factors is given in more detail below.

5.1 The building footprint and layout

The starting point for most floor designs will be a set of basic dimensioned plans showing the building footprint and fundamental layout. The floor designer will use these plans as a framework within which to create the floor design.

5.2 The joist span, direction and floor depth available

Metal web joists can bridge greater clear spans than competing products of the same depth giving the building designer better flexibility for room layout. However, the most important benefit of a metal web joist floor is its ability to facilitate quick and easy installation of the major services.

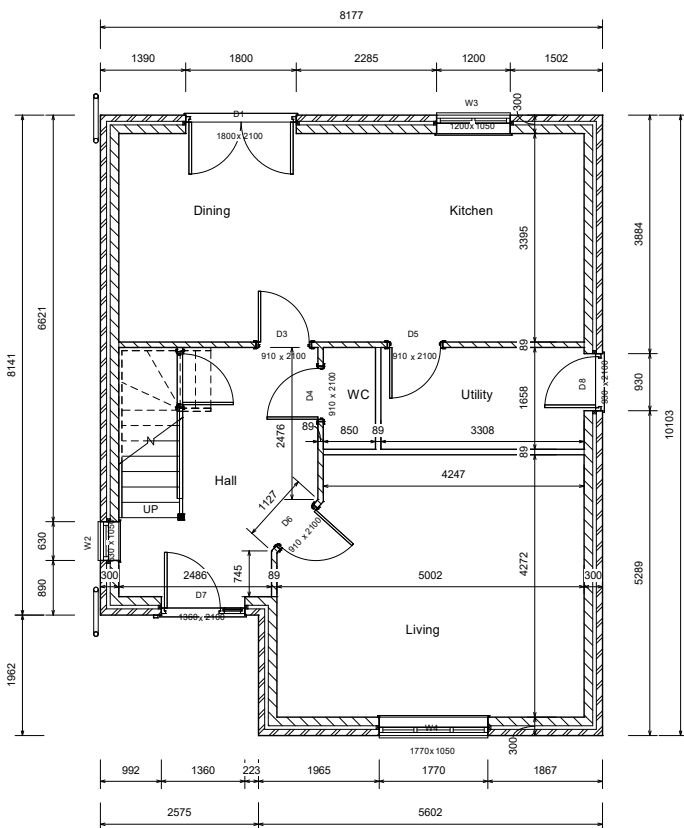

Ground floor layout

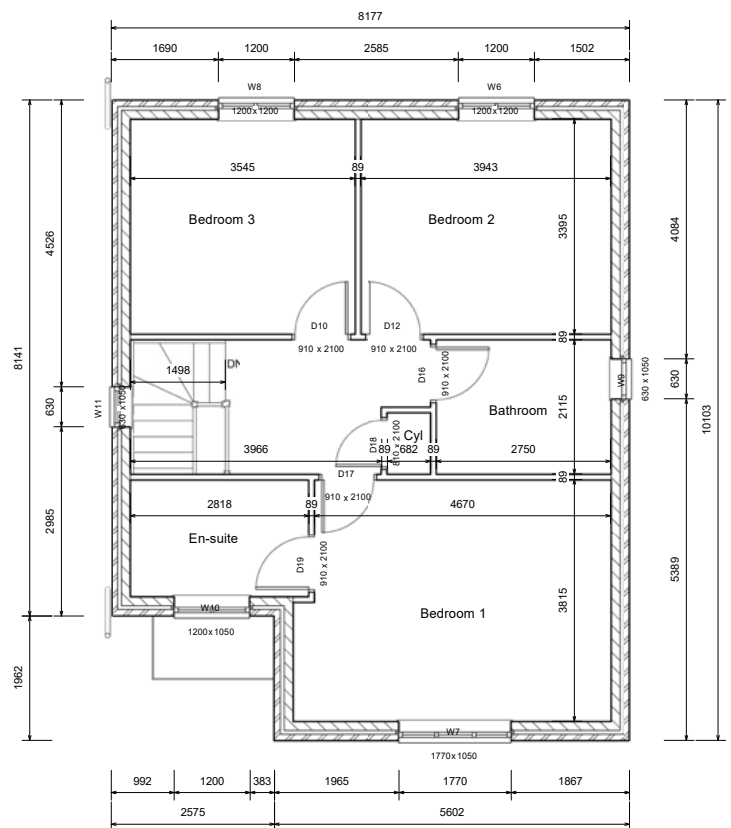

First floor layout

Sizes

Metal web joists are available in a wide range of sizes to suit almost any project. Actual dimensions are dependent on loads, spans and specified centres. While the technology exists to make extra-long joists, in practice length is limited by the practicality of handling and transportation.

Metal web joists are manufactured offsite to your exact requirements to eliminate on site wastage of both time and materials. However, if required they can be supplied with a solid trimmable end to accommodate any minor on site variations.

Flexibility in terms of chord width plus a variety of different depths allows metal web joists to meet customer needs in the most efficient way possible. Some examples of nominal dimensions are given here:

Chord Sizes

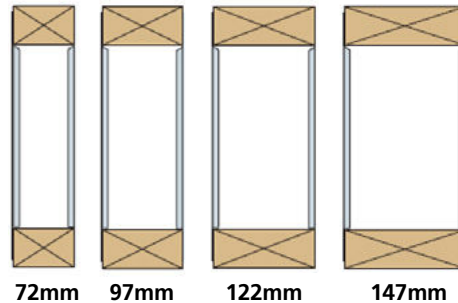

Nominal joist depths

- 200mm
- 225mm
- 250mm
- 300mm
- 375mm
- 425mm

Layout

When used for flooring, joists are typically laid perpendicular to load-bearing walls. However, other configurations may be possible when required to suit openings or other construction details. These should be discussed with the floor designer prior to the design stage.

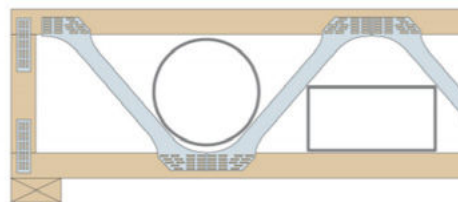

All joists are designed to accommodate a minimum 100mm nominal round soil and vent pipe SVP or rectangular 50mm x 300mm section ducting.

5.3 Design dead load or details of types and weights of floor and ceiling coverings

The most critical aspect of any floor design is to ensure that the correct loadings are defined at the design stage. This will ensure a safe, effective, and cost-efficient floor design for the client.

The design is undertaken with the aid of software, which allows the designer to accommodate both dead and imposed loads applicable to the use and occupancy of the building. The floor designer should be advised of any unusual loads which may be applied to the floor system, e.g. spa baths, snooker tables, hoists etc.

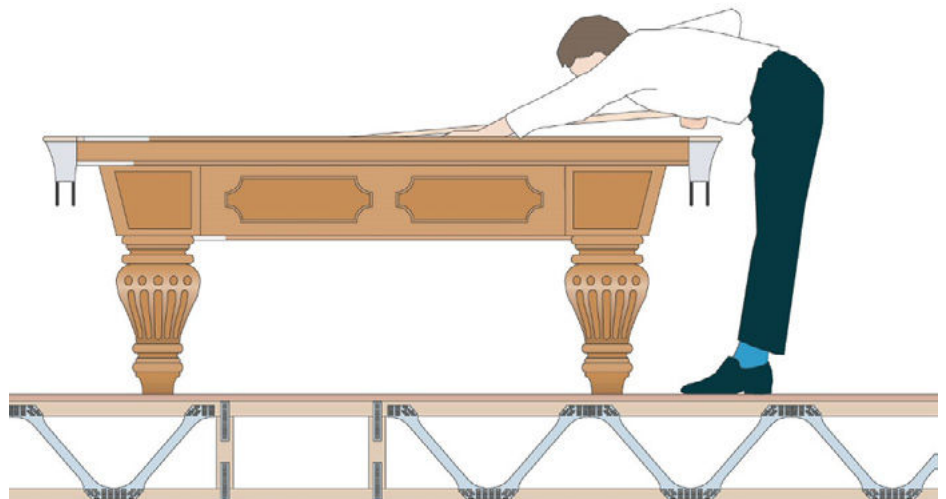

5 Design Considerations (cont.)

5.4 Intended building use and design-imposed loads

Floor systems

A metal web joist floor system can provide longer clear spans, which gives greater design flexibility in locating bearing walls and partitions. This allows the designer freedom to choose a variety of internal room layouts within an external shell.

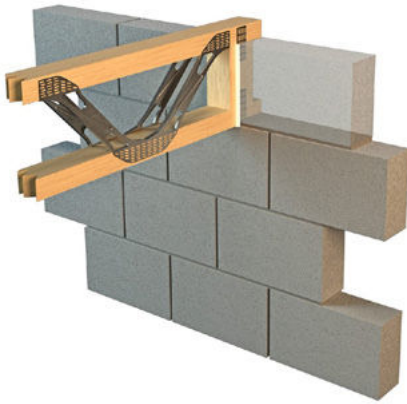

Roof Systems

Metal web joists are suitable for both flat and pitched roofs where, due to their span capability, they can provide an economical alternative to steel, concrete and other materials.



5.5 Position and weight of non-load bearing internal partitions

Metal web joists are designed and manufactured to the specific requirements of each project. A design is dependent on the application and loads applied.

Metal web joists are not designed to support masonry load-bearing walls but can be designed to support lightweight partition walls.

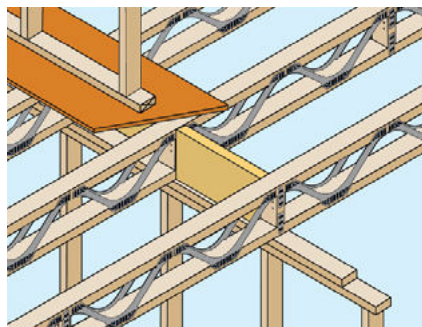
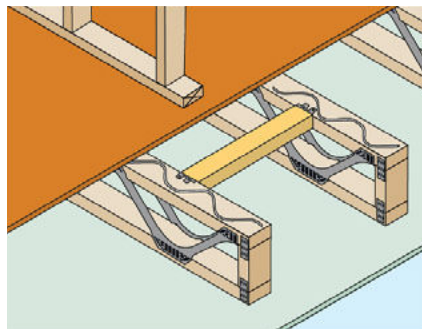

5.6 Other additional loads such as hoist tracks

Building clients are increasingly adding additional loads such as hoists in care homes and adapted living accommodation. Given the significant loads these can impose on the floor zone it is important detailed information on such requirements is included at an early stage of design.



Image courtesy of Astor-Bannerman

5.7 The positions and method of support at all bearing positions e.g. hangers or built-in

Metal web joists can be designed to be supported on either the bottom chord or the top chord and can be built into supporting elements or connected via joist hangers. Several typical support details are shown below for masonry and timber frame construction.

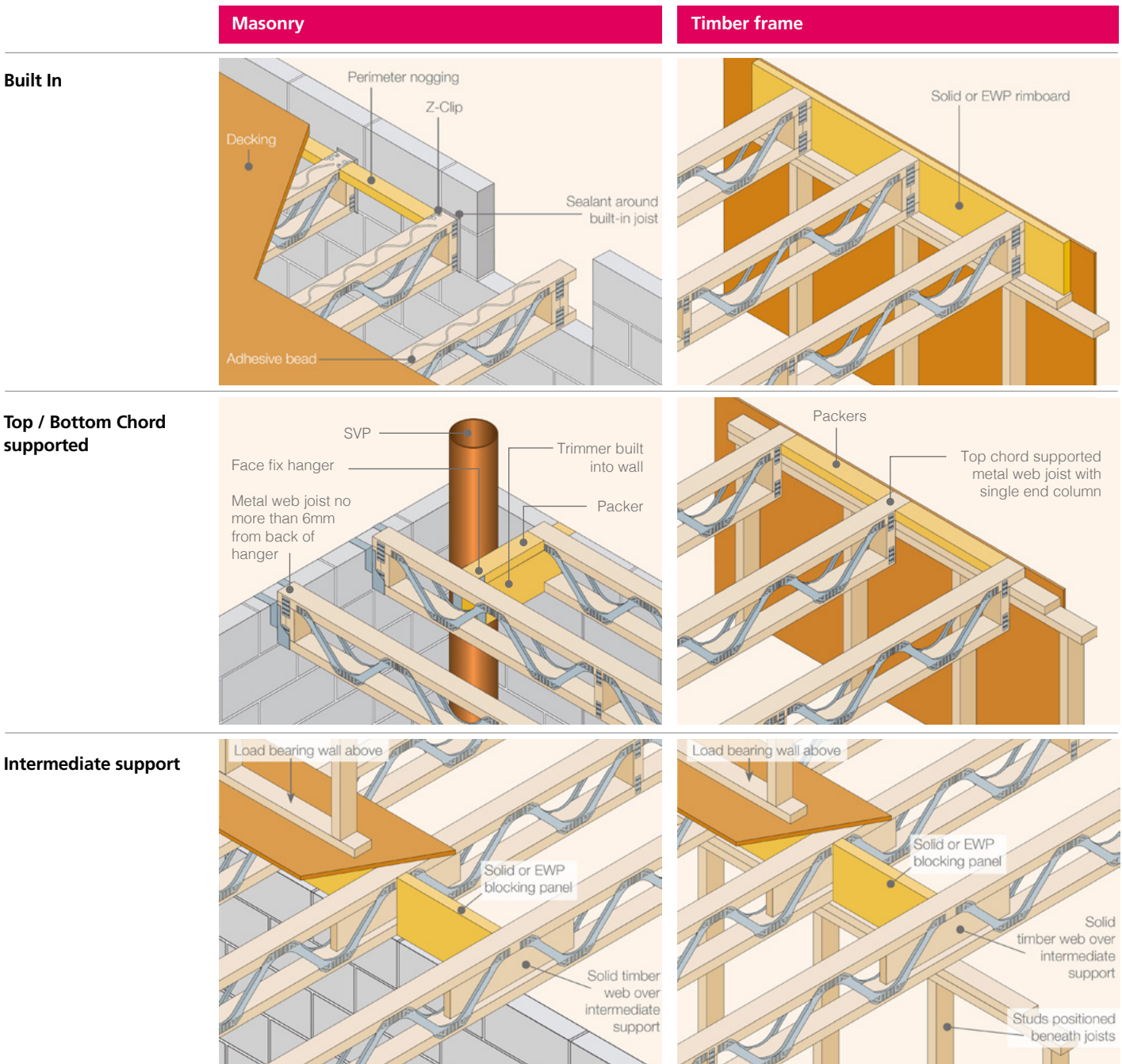

5 Design Considerations (cont.)

5.8 Any special requirements for floor members e.g. specific chord widths, joist spacing or deflection requirements

Floor vibration

Specific customer requirements regarding floor vibration or deflection limits should always be discussed with the floor designer.

Herringbone strutting is not required with metal web joists. Where the span exceeds four metres a strongback is normally used to dampen vibration by increasing the stiffness of the floor and reduce deflection by load sharing. TRA members can provide guidance on installation.

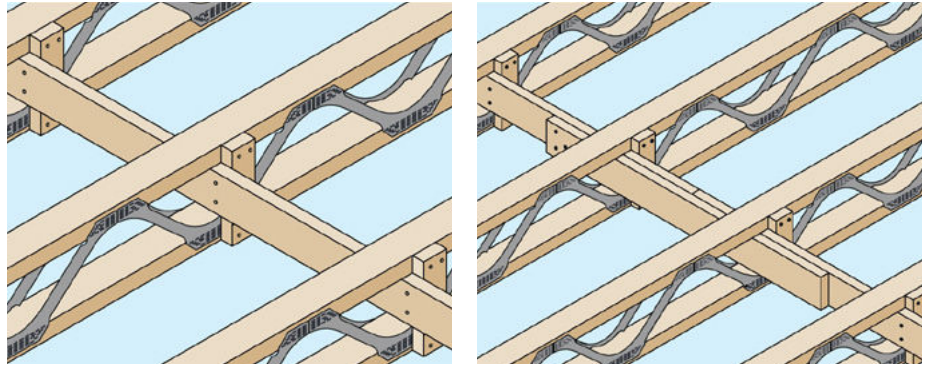

5.9 Size and location of required floor openings e.g. stairs

The location, size and type of stair or other openings within the floor area is one of the most critical aspects of design in order to transfer the loads and deal with the practicalities of creating the opening through the use of trimmers and girders or multiple metal web joists.

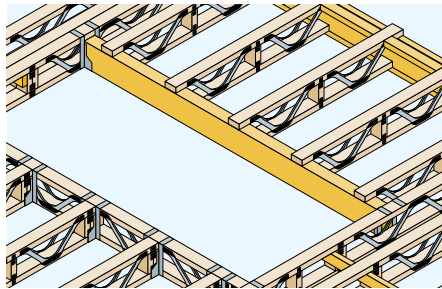

5.10 Size and location of large or non-standard services planned to be run through the floor zone

Easy access to services

One of the major benefits of using metal web joists is that they are designed to easily accommodate services and utilities within the floor void area without the need for any cutting, notching or drilling. If it is necessary, this should never be undertaken without the joist manufacturer's approval. Joist depths may be varied to suit particular duct requirements.

5.11 Other considerations

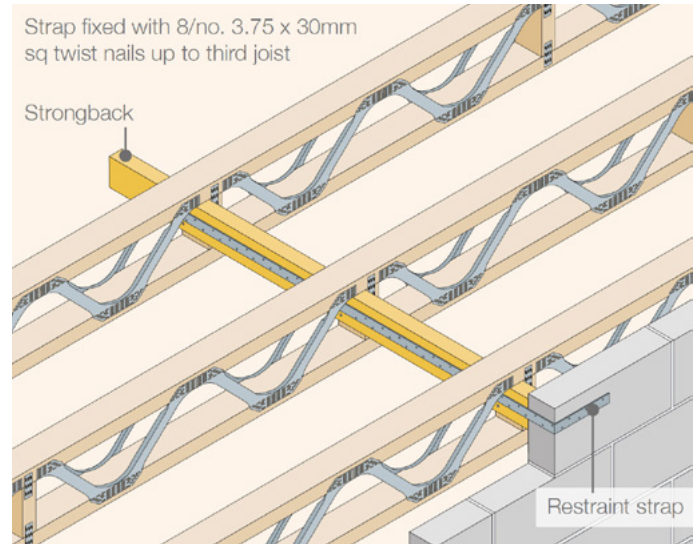
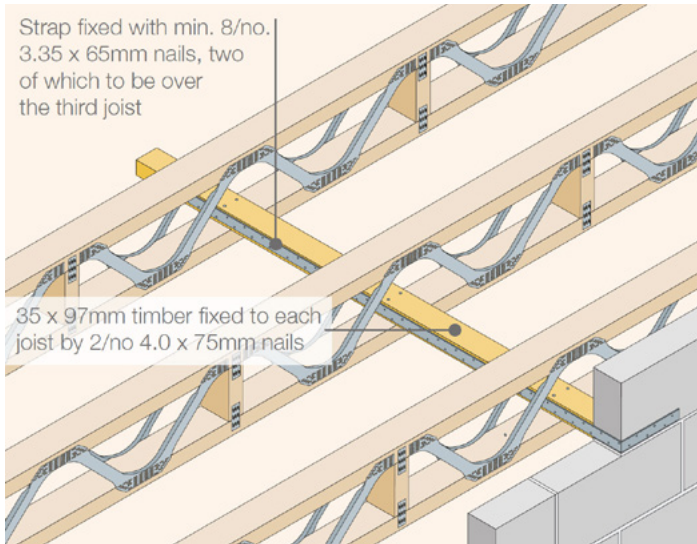

Horizontal restraint straps

Horizontal restraint straps are used to tie the walls to the floors and should be fixed to perimeter walls in accordance with the building designer's instructions.

Preservative treatment

Metal web joists do not normally need to be preservative treated when used in floor constructions where the environment is likely to be classified as Use Class 1 or 2 as defined in Eurocode 5.

However, if the joists are to be used in situations where preservative treatment may be required, then the TRA member's advice should be sought and any preservative treatment used should not adversely affect the corrosion resistance of the metal webs or plates.

Fire and acoustics

Metal web joists fully comply with all relevant standards in relation to fire and acoustics.

Standard generic details have been developed to address the most common aspects of design, and are available through the Robust details' handbook in terms of acoustics and from your chosen metal web joist supplier in terms of defined 30 and 60-minute tested fire solutions.

6 Essential metalwork for floor systems

Specification and use of the correct metalwork is essential to achieve the floor performance as designed. TRA members are your expert partners who can help to identify and provide the right products for the job.

Hangers

Metal web joists must be correctly supported using the appropriate hanger. There are specific hanger variants for timber to timber and timber to masonry connections. There are also further variants for circumstances where there is limited masonry above the connection point. Always ensure the correct fixing schedule is followed and all the necessary fixings are applied.



Timber to timber

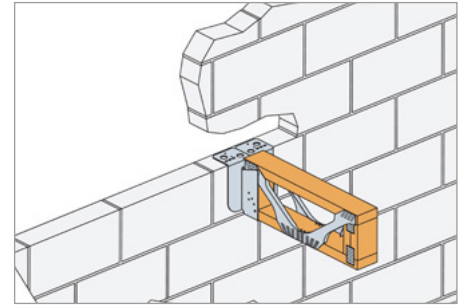

Timber to masonry

Restraint

Lateral restraint is essential to connect walls and floor elements. Specification of the correct arrangement for restraint is the responsibility of the building designer, but TRA members can assist in identification and supply of both perpendicular and parallel lateral restraint metalwork.



Perpendicular lateral restraint



Parallel lateral restraint

Multiple joist connections

2-ply joists are typically used around openings where greater stiffness is required for oncoming point loads etc. It is essential that the correct connection detail is used to ensure this unit acts as one rather than two halves moving against each other which can cause excessive deflection in the floor. TRA members will provide specification details using structural screws or clips as an essential element of the floor design. They will also be happy to supply the appropriate connectors as part of the delivery package.



Structural screw connection

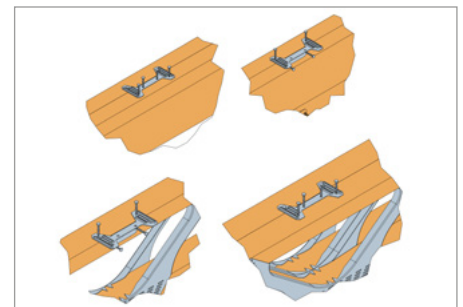

Structural clip connection

Ancillary metalwork

Selection of the right metalwork will increase the efficiency of metal web joist installation and ensure the correct connection is made first time every time.

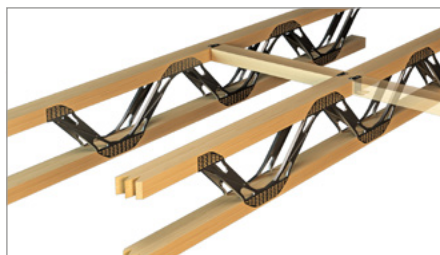

Nogging support clips

7 Site handling, storage and installation

The TRA manufacturer will take responsibility for the safe loading and delivery of metal web joists. The responsibility for the safe unloading and handling, once on site, and the installation is the responsibility of the contractor. However, to assist the contractor, the TRA member will supply you with the delivery, and on request, general guidance on their storage, handling and installation.

Metal web joists are delivered in tightly banded packs to facilitate mechanical handling which is the recommended method for unloading and movement whilst on-site.

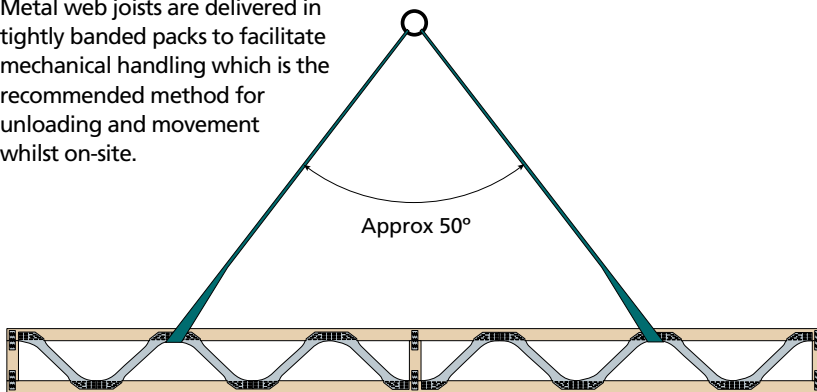

Handling

Site handling safety guide:

1. When unloading with a crane, fabric slings should be attached to the timber chords or lifting points and not the metal webs. Metal chains / slings should not be used
2. Slings should be attached to the panel points closest to the quarter points
3. If unloading with a forklift, care should be taken to ensure that the forks do not damage the joists
4. Joists may be lifted as either single units or packs, but care should be taken to avoid bending, twisting or dropping
5. Metal web joists should be lifted in a vertical position.

Storage

Site storage guide:

1. Site storage is intended to be temporary immediately prior to installation so delivery should be arranged to minimise storage time
2. Metal web joists should be stored on firm level ground well clear of any vegetation
3. They should be protected with a weatherproof covering to protect them from short term exposure to inclement weather
4. Metal web joists can be stored either vertically or flat. If stored vertically there should be adequate bearers under the node points. If stored horizontally they should be supported to prevent distortion.



7 Site handling, storage and installation (cont.)

Construction materials shall only be stored in the 1.5m edge zone at one end of the joist only. Max height 250mm.

Joists supported by masonry hangers to have a minimum 675mm cured masonry above hanger level or as advised by hanger manufacturer

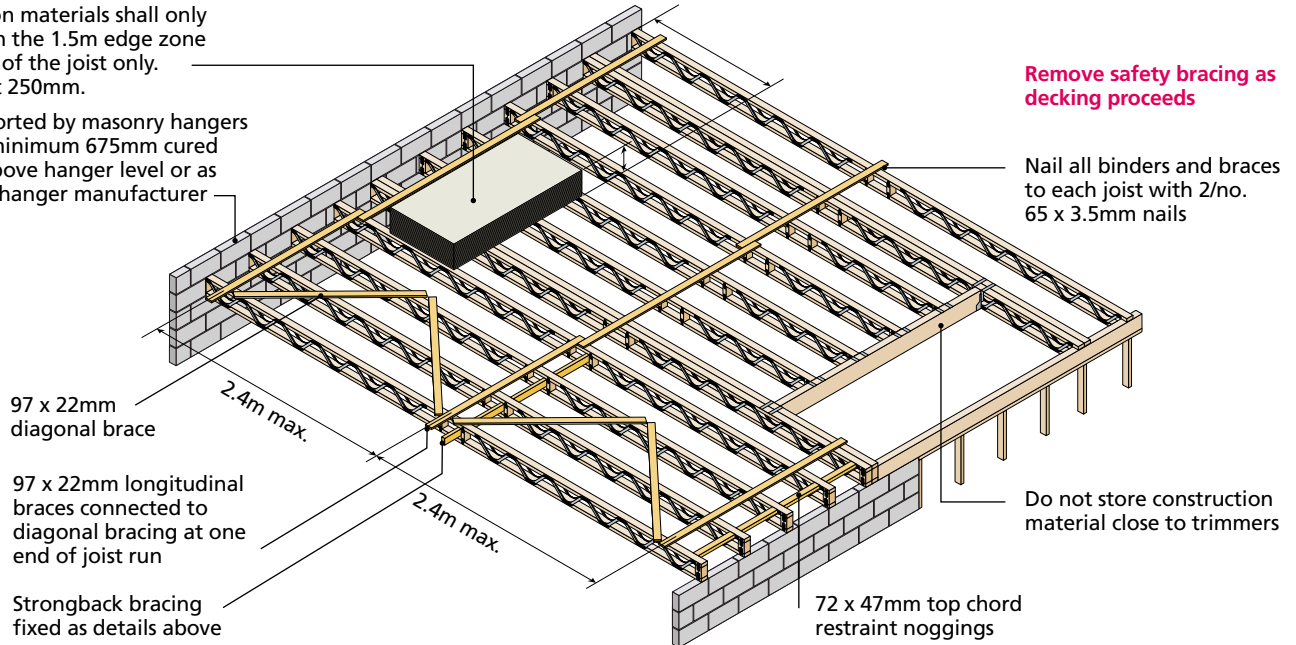

Temporary bracing

This diagram indicates temporary erection bracing only. It is applicable to both masonry and timber frame construction. Decking can be laid in lieu of diagonal bracing.

Installation

Site installation guide:

1. Before installing the joists, decide on which area of floor is to be installed first and from what end
2. Use the layout drawing provided by the manufacturer to place joists in the correct area of the building
3. Check the end details of joists and if any internal support is needed. If needed, ensure the correct orientation of the joist before raising to floor level
4. The top chord will always be identified on each joist and users should ensure every joist is installed the correct way up
5. Use hoisting straps around the timber chords, not around the metal webs when raising to floor level
6. Spacing is defined by the designer on the layout drawing supplied and must not be increased by the installer
7. Strongbacks should be inserted before the joists are fixed, as it may not be possible after fixing
8. Do not walk on unbraced metal web joists as they may be unstable
9. Do not store building materials on unbraced metal web joists
10. Temporary diagonal bracing laid at 45° and installation of the permanent strongbacks should be used to stabilise the metal web joists
11. Care should be taken to ensure that the specified spacings and bearings are maintained
12. Care should be taken to ensure that joists are level along their lengths and across the floor and that each is correctly supported
13. All bearing positions should be level and firm and provide the specified minimum bearing area
14. Temporary bracing may be removed as floor decking is installed in each section.

8 Do's and don'ts of handling, storage and installation of metal web joists

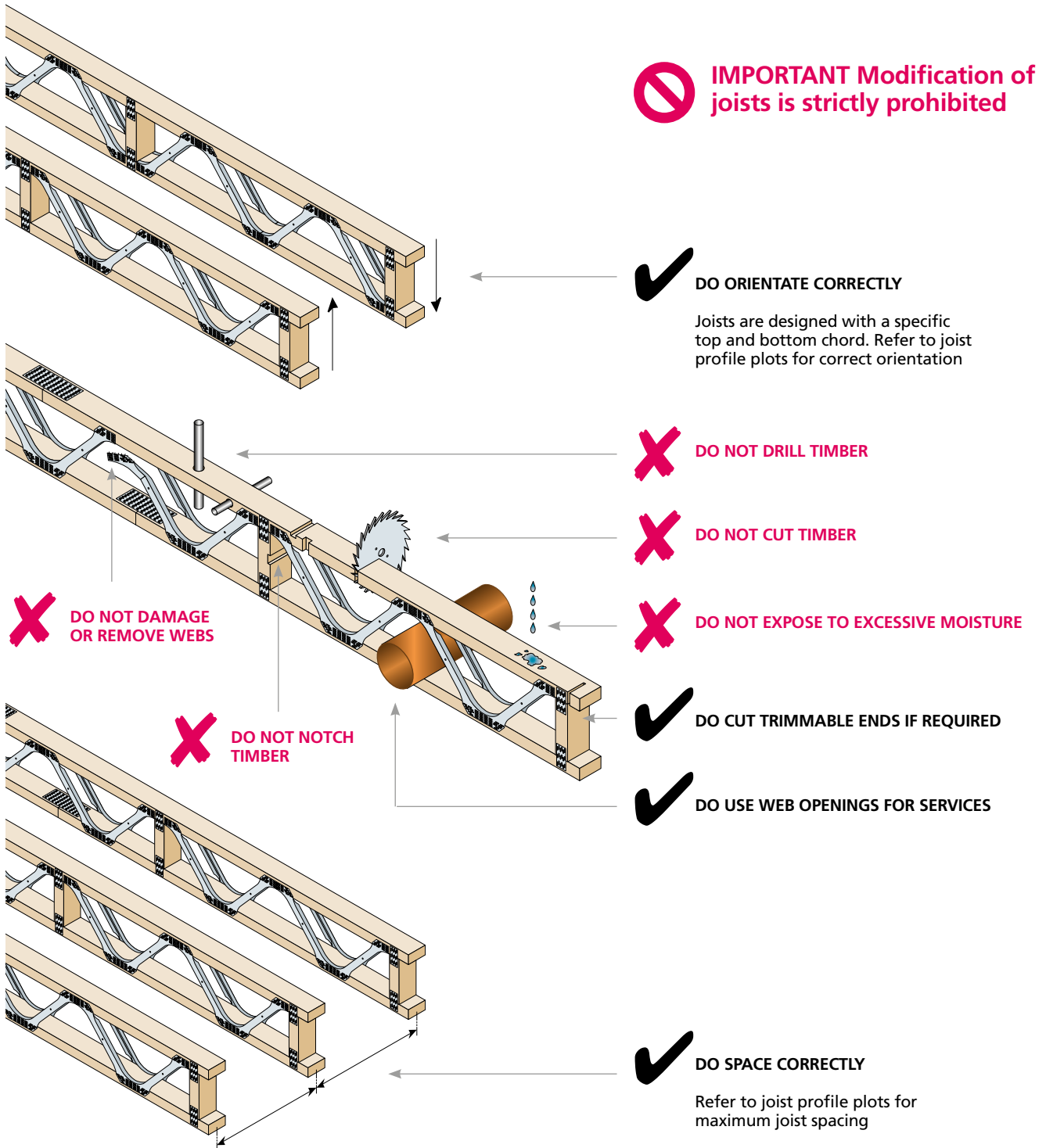

8 Construction checklist

For buyers and contractors who are responsible for the installation of metal web joists, the TRA has produced the checklist below as a useful guide of the construction elements which need to be inspected to ensure a safe and correct installation.

Any points on the list that are checked as 'no' must be addressed and rectified before work proceeds.

	Yes	No
Metal web joists		
Correct quantity, positions and orientation		
Centres not greater than specified		
Ensure all joists "Top Side" up		
Adjacent joists are level with each other and the ends of the joists form a straight line		
Joists should be erected straight and vertical		
Horizontal deviation: 10mm max		
Vertical deviation: 2mm max		
Ensure support condition as per drawings		
All joists are fully bearing on their supports properly seated on wall plate, hangers etc.		
All strongbacks are correctly positioned according to drawings installed tight to underside of top chord and fixed in accordance with specification		
No damage or unauthorised modifications to joists or other floor components		
Girders/multiple MWJ and stair trimmers are correctly positioned and connected exactly in accordance with specification		
Any additional restraint required correctly installed and fixed		
Correct thickness and width of floor deck installed and fixed in accordance with specification		
	Yes	No
Structural metalwork		
Hangers correct to specification and fixed as specified		
Restraint straps present and correctly fixed, including packing where required between members		

Notes



**TRUSSED RAFTER
ASSOCIATION**

Visit our website for more information: tra.org.uk or traireland.ie

The Building Centre
26 Store Street
London
WC1E 7BT

T: 020 3205 0032
E: info@tra.org.uk

The latest version of this guide can be downloaded online at tra.org.uk or traireland.ie

All information is correct at the date this guide was produced. We reserve the right to make technical changes at any time.