

Gable Wall Spandrel Panels

This guidance relates to pitched trussed rafter roofs above masonry with an unoccupied, cold roof space and insulation at ceiling level.



Gable wall spandrel panels

Gable wall spandrel panels are an offsite manufactured product. They provide an alternative to the inner leaf of an exterior masonry wall at the gable end of a building. The panels must be designed to comply with structural, thermal and fire resistance (where required) performance standards and current building standards and regulations. As gable wall spandrel panels do not separate habitable spaces, defined acoustic requirements are not applicable.



Images courtesy of Pasquill, Crendon, ITW and Saint-Gobain

Please note this document does not cover:

- Twin wall constructions where both inner and outer leaves of masonry are replaced by gable wall panels
- The use of cladding systems other than brick.

These areas will require separate design and detailing.

To assist Building Designers and Contractors, this document sets out some essential guidance on aspects of gable panel design, construction and installation for usage above masonry. All images are for illustrative purposes only. The recommendations contained within this document are supplied in good faith but without liability and their use shall be entirely at the risk of the user.

Contents

01. Design responsibilities	02
02. Structural considerations	03
03. Fire resistance	04
04. Thermal performance	05
05. Manufacture of panels	06
06. Site handling details	07
07. Installation	08
08. Gable lateral restraint	11
09. Staying safe	12

1 Design responsibilities

Getting the design right on any part of a building is key and for roofing it's essential that all involved with the design, manufacture and installation of gable wall spandrel panels are working together effectively.

Guidance published in PD 6693-1 for the UK and SR 70 for Ireland states: "On every project, it is essential that one person assumes overall responsibility as building designer and is clearly defined as such."

PD.6693-1 then goes on to specifically state: "The building designer should be responsible for ensuring the integration of the design of the various building components including the detailing of suitable connections between the building components and their support structure. The building designer should be responsible for ensuring adequate provision is made for the stability of the building, as distinct from, and in addition to, the stability of individual components, including the detailing of all elements of bracing required in the building."

On each project, there should be a clear understanding of who is responsible for the building design and who is responsible for the roof design and/or the elements within it, such as trussed rafters, party wall spandrels and gable wall spandrel panels. Information sharing is key to the process and the responsibilities for each designer can be found within Annex A in PD 6693-1 and section 10 in SR 70.



The building designer should ensure that the necessary information is provided to all parties involved in the design of the building.

Where specified for supply, gable wall spandrel panels will be engineered by the manufacturer to meet stated requirements and withstand the specified design loads provided by the building designer. These will include wind loads – both pressure and suction – and the acceptable/permitted deflection limit of the outer leaf of masonry.

As stated above, the building designer is responsible for detailing a suitable connection between the building components (in this case the masonry wall below, the wall plate and the gable wall spandrel panel above) and their support structure (in this case the restraint of the external wall to the roof). Information in this guide is intended to assist the building designer in this process and provide guidance on how gable wall spandrel panels are manufactured, handled and can be installed.

2 Structural considerations

Gable wall spandrel panels must resist wind loads acting on the gable end walls and any loads imposed by the outer layers of cladding. These loads are transmitted through the panel to the roof structure via lateral restraints.

This guide provides information in relation to single leaf gable wall spandrel panels supported on the inner leaf of a masonry cavity gable wall. This is a simpler alternative to that defined (as type 5) within the NHBC Technical Guidance 7.2/25 on spandrel panels to cold roofs - January 2018.

Gable wall spandrel panels require robust lateral connections from the gable wall to the roof trusses at rafter and ceiling level to effectively transfer loads to the main trussed rafter roof structure. In turn, these loads (tensile and compressive) are transferred through the top and bottom chords of the trusses to the side walls of the building.

This transfer of loads is most effectively achieved using a structural timber wall plate, which is run continuously around the external walls of the building with the trussed rafters and the gable wall spandrel panel fixed at the same level. As an alternative, the structural timber wall plate may be stepped and raised at the gable end. However, doing so introduces some complexity to the design and construction process. Lateral loads should not be unduly applied to the webs of trussed rafters, unless specifically

designed for. For most applications, lateral loads should be applied only to the top and bottom chords.

Lateral restraint can be provided by:

- Metal restraint straps fixed to the panel and to noggings, or timber bracing fixed to the bottom or top chord across a minimum of three trussed rafters.

Structural calculations should be provided by the building designer to support the chosen method of lateral restraint. Restraint strap requirements illustrated in this guidance, either at ceiling level or along the rafters are to be in accordance with Approved Document A or equivalent, and BS8103. Examples of lateral restraint which are fully supported by such calculations are provided in this document (see section 8).

Gable wall spandrel panels should be installed level with the top of the trussed rafters for flush roof verges; or to underside of gable ladders with boxed verges.

Timber frame to masonry wall ties are essential to transfer loads between the outer masonry leaf and the structural frame of the gable wall spandrel panel. Specifications should be clear whether provision of such wall ties form part of the gable wall spandrel panel supply contract.

A structural connection is required between the wall plate and the inner leaf of masonry.

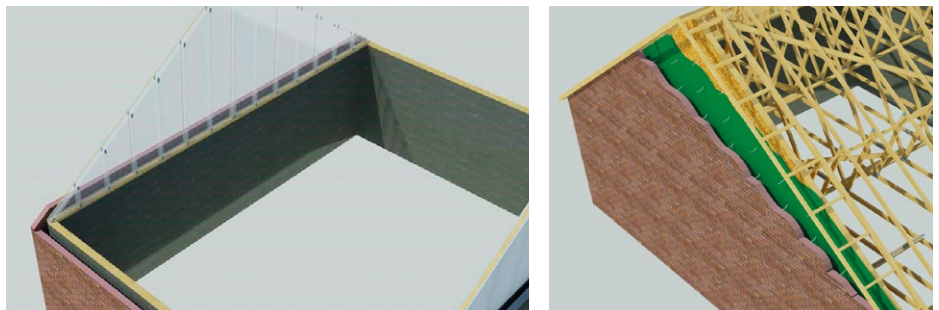

Trussed rafters not shown to aid illustration

3 Fire resistance

Fire protection to gable wall spandrel panels is dependent on the dwelling type, and distance from relevant boundaries. Based on Approved Document B1 (England) and 100mm thick masonry outer leaf the fire protection described below would generally apply:

The building designer should determine the fire protection requirements for the project in association with the appropriate regulatory bodies.

Fire protection requirements by dwelling type are:

Three storey houses and two storey flats:

- Requirement B4 – External spread of fire may apply if the building is close to a boundary and the area of the gable wall spandrel panel is larger than the allowable ‘unprotected area’ of the plot.

Where a 30-minute period of fire resistance is needed, an unlined gable wall spandrel panel with 100mm masonry outer leaf is considered to meet this requirement.

Houses and flats with height exceeding the above dwelling types:

- Requirement B4 – External spread of fire may apply if the building is close to a boundary and the area of the gable wall spandrel panel is larger than the allowable ‘unprotected area’ of the plot. A 60-minute period of fire resistance is needed. An unlined gable



wall spandrel panel and 100mm masonry wall is NOT considered sufficient to meet this period. In these circumstances, the building designer must work with the contractor and manufacturer to determine what additional site-applied measures, such as internal linings to the gable wall spandrel panel, are necessary to achieve the required fire protection.



4 Thermal performance

Indicative calculations have been undertaken to demonstrate the performance of a gable wall and cold roof thermal bridge detail, incorporating a timber spandrel panel, in place of an internal leaf of masonry blockwork. On the basis of the modelling undertaken, all scenarios demonstrate compliance with the minimum surface temperatures/ fR_{si} requirements of BR 497:2016 and the associated heat loss (ψ /Psi-value) for use in SAP calculations has been communicated.

Generic modelling on behalf of TRA demonstrates that additional cavity insulation should not be required above the trussed rafter wall plate level to achieve the required U-values with timber frame gable wall spandrel panels. Furthermore, indicative calculations suggest the generic construction details in this document can provide thermal performance comparable with the basic Accredited Construction Details for masonry walls.

Building designers should ensure that plot specific thermal bridging and SAP calculations are undertaken based upon the exact construction details used.

Care should always be taken during construction to minimise the risk of thermal bridging.

To ensure the ceiling maintains a consistent U-value through to the gable wall, loft insulation shall be laid tightly abutting the inner face of the sheathing panel. Unless specified by the building designer, additional cavity insulation is not usually required with timber frame panels to achieve the required U-values and should be avoided due to the risk of interstitial condensation.

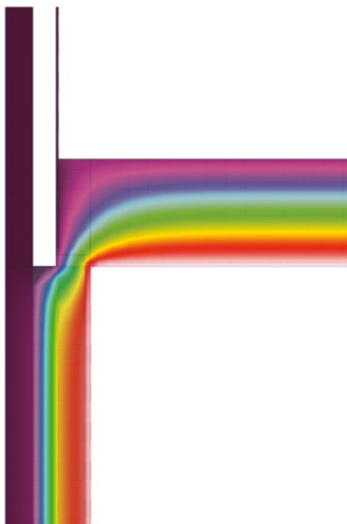

100mm full fill insulation below gable detail open cavity

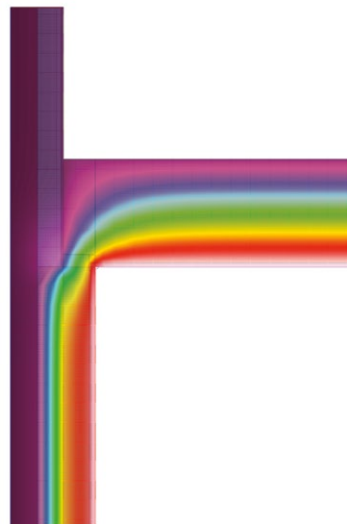

100mm full fill insulation below gable detail closed cavity

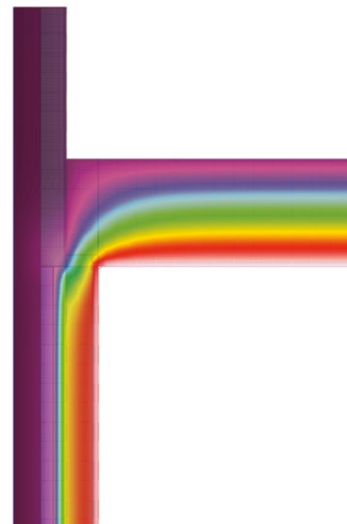

100mm partial fill insulation below gable detail

5 Manufacture of panels

Panels are constructed in the factory using structural timber-frame members with pressed steel plate or nailed joints. They are clad on one side with structural sheathing board, which is covered with a breather membrane to prevent moisture ingress from the cavity during designed service life.

Single piece gable panels are recommended wherever possible, to minimise the need for working at height on site. Offsite manufacture shall be subject to third-party accredited, quality-assured factory production control.

Engineering will be supported by design software and/or structural calculations, including nailed joint specifications, to confirm the gable wall panel will meet specified design loads provided by the building designer. Calculations should also ensure that structural integrity is maintained during handling, delivery, crane offload and site installation.

Structural timber-frame members must be a minimum section size of 89 x 38mm or 97 x 47mm with nailed connections or 72 x 47mm where joints are plated. Vertical studs must be at maximum 600mm centres, with horizontal noggings as required to provide structural integrity and fully support the edges of the sheathing boards. All structural timber members must be at a minimum strength class of C16 or higher, where required by engineering calculations. If necessary, all structural timber frame members are to be preservative treated to Use Class 2 and a desired service life of 60 years.

Panels must be clad on one side with structural sheathing board. This is most commonly 9mm-thick OSB Class 3 or 4 to meet BS EN300, or an alternative as required by engineering calculations. Boards must be fixed to the structural timber frame using minimum 2.9mm x 50mm nails at 150mm centres on the perimeter of the sheathing sheets and at 300mm vertical spacing elsewhere.



The breather membrane specification must be in accordance with the building designer's requirements and in accordance with NHBC Standards: Clause 6.2.13. A membrane must be fixed to the outer surface of the sheathing in accordance with the manufacturer's recommendations. An additional minimum of 200mm of breather membrane must be provided at the foot of the panel. This material must be folded back and lightly tacked in place to secure it during delivery. At installation, the material is released and used in accordance with accepted details to suit partial or fully filled cavity insulation. An illustration is included in this guide. The position of studs must be highlighted with tape or marker pen on the outer surface of the breather membrane to assist site



installation of the wall ties between the timber frame and masonry wall.

Gable wall panels are to be supplied with factory-fitted, weight-tested lifting straps suitable for the condition in which the panels are delivered. The weight of each panel must be clearly marked on the panel itself.

6 Site handling details

Gable panels should be moved using mechanical handling only.

Installers and contractors must provide site-specific risk assessments and method statements for the site handling, crane lifting and safe installation of gable wall panels.

Panels should be stored upright only, supported on bearers out of ground contact and safely restrained to prevent injury.

Panels should always be given adequate weather protection on site. Any panel(s) that are unprotected or have suffered significant bowing or wrapping due to excessive exposure to adverse weather should not be used/installed in the final build.

Further information on the safe unloading of spandrel and gable wall panels can be found on the [TRA website](#).



7 Installation

The installation of gable panels is most easily achieved using a structural timber wall plate, which is run continuously around the external walls of the building with the trussed rafters and the gable wall spandrel panel fixed at the same level. See Figure X below.

Single-piece panels are recommended wherever possible to minimise the need for working at height on site. Where panel sections are jointed, additional quality checks will be needed to ensure the correct alignment of the panel sections and that fixing is in accordance with the manufacturer's fixing schedule.

Timber frame to masonry wall ties must be site-fixed into the structural timber frame members of the gable wall spandrel panel, in accordance with NHBC Standards Chapter 6.1.18 and Detail 10 of NHBC

Technical Guidance 7.2/25. The position of studs should be highlighted with tape or marker pen on the outer surface of the breather membrane to assist with this site installation.

During installation, the lightly fixed bottom edge of the breather membrane must be lifted and positioned to accepted detail over the cavity insulation. This ensures that penetrating water in the cavity can be directed away from the building interior, as illustrated in this guide. Decisions on the use of cavity trays

and fire resisting cavity barriers at ceiling level rest with the building designer.

For the connection between the wall plate and the masonry:

- Proprietary metalwork connection with proven performance values accepted by NHBC/TRA must be used
- The maximum spacing of connectors is dependent on wind loading and site location
- See section 8 for examples of connection details.

Figure X: Timber Gable to Masonry fixing detail to cold roofs - **continuous wall plate***

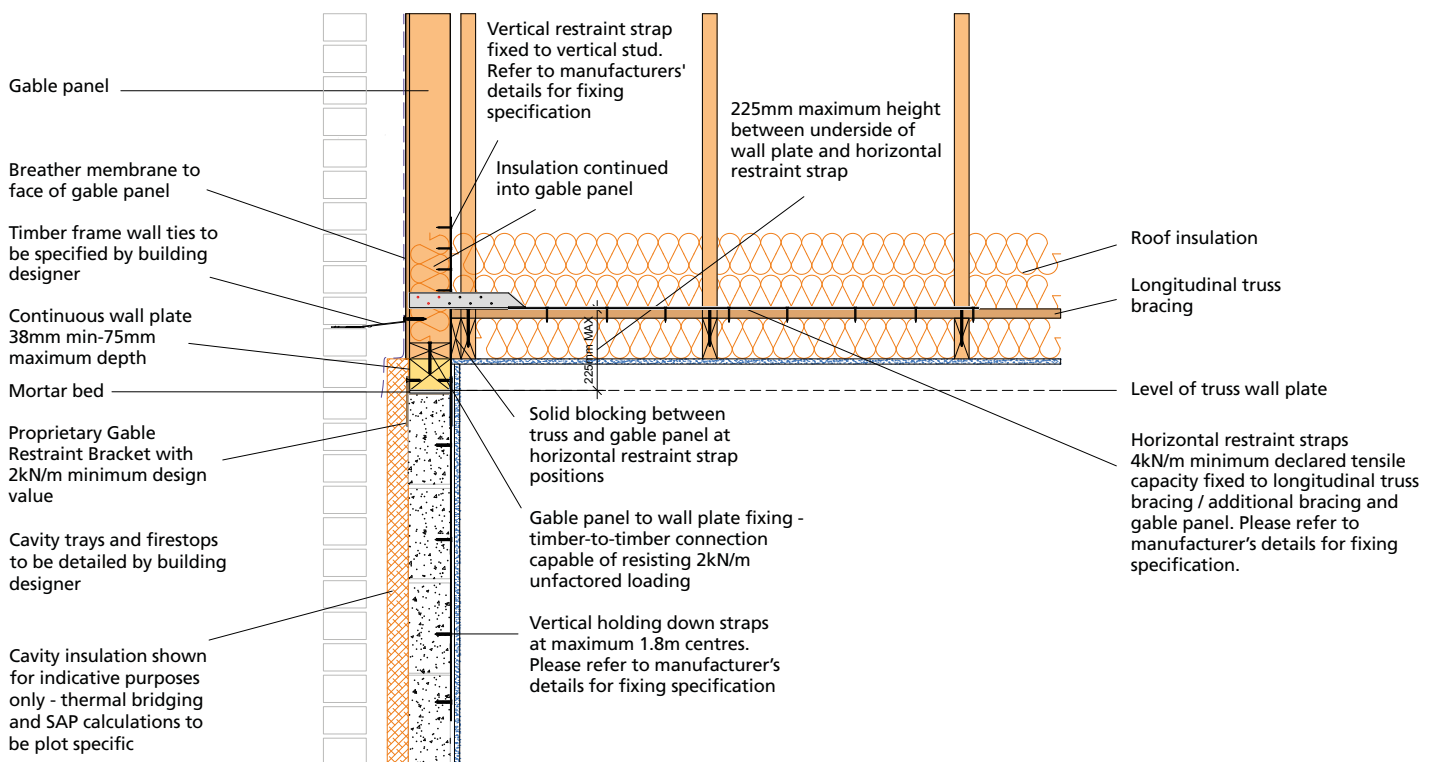

Straps, brackets and fixings centres to be specified by building designer or refer to product details

*Typical loads shown in the above detail applies only to buildings of up to three storeys in England and Wales, and two storeys in Scotland.

For the connection between the wall plate and gable panel bottom rail:

- Timber to timber connection capable of resisting appropriate unfactored loading. See section 8 for examples of manufacturers who can provide connection details.

For the restraint at ceiling level:

- Bracing members to be nominal 25 x 100mm with a minimum cross-sectional area of 2,134mm² and a minimum target thickness of 22 mm
- Longitudinal truss bracing must be laid in line and butted tight against the vertical studs of the gable wall panel

and fixed to a minimum of three trusses using 2no x 3.1mm x 65mm nails at each truss

- A horizontal twisted restraint strap must be fixed to the side of a vertical stud in the gable wall panel and fixed to the longitudinal bracing
- The maximum spacing of restraint straps is dependent on the site location. Please refer to manufacturer's details for fixing specification
- See section 8 for examples of connection details.

As an alternative, the structural timber wall plate may be stepped and raised at

the gable end - as illustrated in Figure Y. However, doing so introduces some complexity to the construction process.

The critical requirement here is that the inner leaf of blockwork needs to be accurately cut to align with top edge of longitudinal bracing to prevent the need to bend the angled restraint straps out of level.

Finally, typical restraint strap requirements along the roof slope at rafter level are illustrated in Figure Z.

See section 8 for examples of connection details.

Figure Y: Timber Gable to Masonry fixing detail to cold roofs - raised gable wall plate*

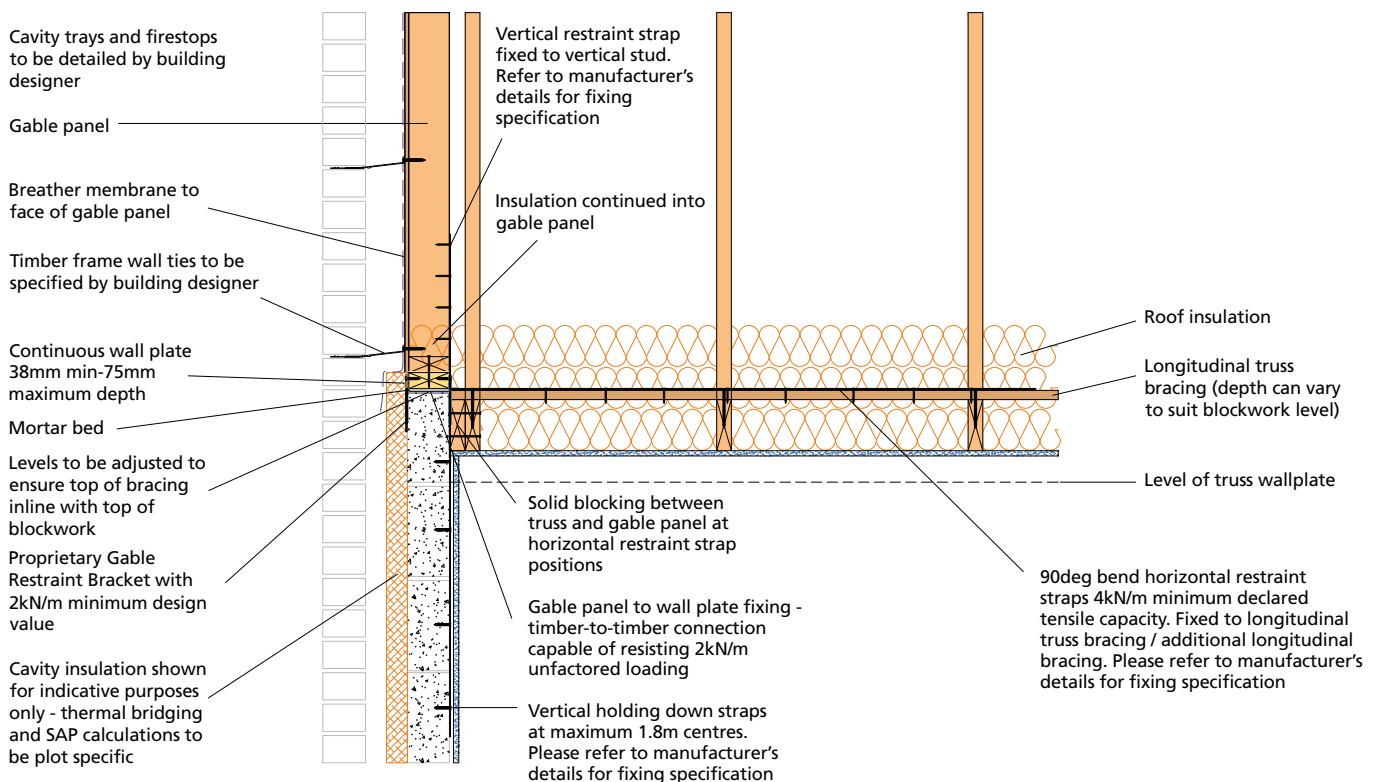

Straps, brackets and fixings centres to be specified by building designer or refer to product details

*Typical loads shown in the above detail applies only to buildings of up to three storeys in England and Wales, and two storeys in Scotland..

Figure Z: 7 For restraint at rafter level

90deg bend Restraint Straps located at, or near to apex and down the rafters at maximum 2m centres (no more than 1.25m centres for buildings over three storeys in England or Wales or over two storeys in Scotland)

90deg bend Restraint Straps to hook over gable panel and be fixed to outer face of the solid timber noggins and trussed rafters. Refer to manufacturer's specification for fixing details

Gable panel

Breather membrane to face of gable panel

Timber frame wall ties

Solid timber noggins, minimum 38mm wide, fixed between the first three trusses with solid timber blocking between the final truss and the gable panel at the strap locations

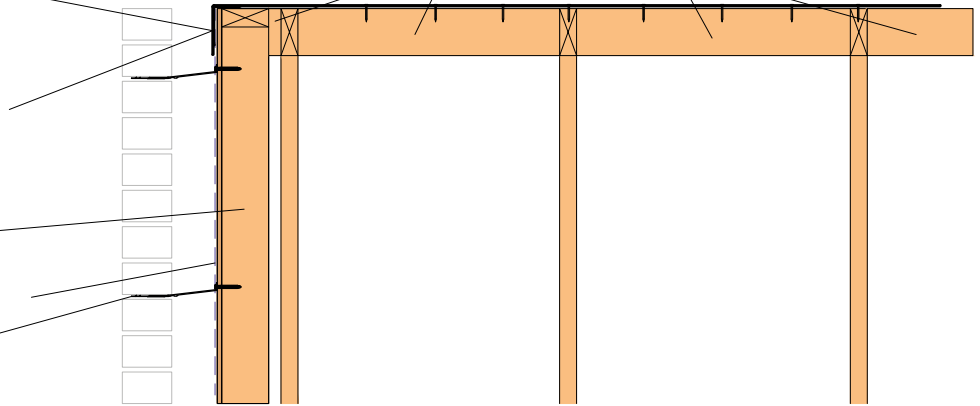

Where a gable ladder is used, the 90deg bend Restraint Straps hook over a reduced gable panel and are fixed to the inner face of the solid timber noggins and trussed rafters, with the gable ladder above. Refer to manufacturer's specification for fixing details

Gable panel

Breather membrane to face of gable panel

Timber frame wall ties

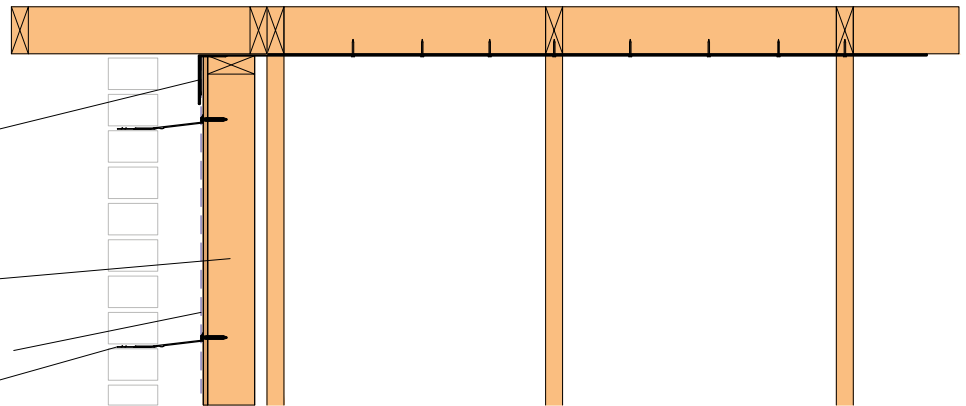

Cavity trays and firestops to be detailed by building designer

Straps, brackets and fixings centres to be specified by engineer or refer to product details

8 Examples of proprietary gable bracket/connector

8.1 Cullen gable restraint

ITW Construction Products' Cullen brand of timber engineering connectors has been synonymous with innovation and quality for over 40 years. In collaboration with national housebuilders, the Trussed Rafter Association and industry partners, its technical experts have created an innovative system featuring the Cullen Gable Restraint Bracket for a complete solution to connect timber gables to masonry walls. The details have been developed to safely transfer lateral wind load on the masonry and timber gable ends into the braced roof diaphragm. This provides a verified connection between timber gable panels to masonry walls. The details give an option to have a continuous wall plate or a stepped wall plate with the gable wall plate being raised to suit the bottom chord depth of

the truss. Either of the details meets the minimum requirement of Building Regulations 2010 approved document A, Scottish Building regulations domestic, NHBC Standards for houses of five storeys or less – England and Wales and four storeys or less – Scotland. Both details are accepted by NHBC.

An NHBC accepted "whole system" solution incorporating the Cullen Gable Restraint Bracket and restraint straps including Paslode nail fixings with all centres, spacings and connections already calculated assures of compliance along the value chain. If Cullen's details are fully adopted, no further checking is required to ensure the safe transfer of lateral wind load on the masonry and timber gable ends into the braced roof diaphragm.

Click here for digital brochure

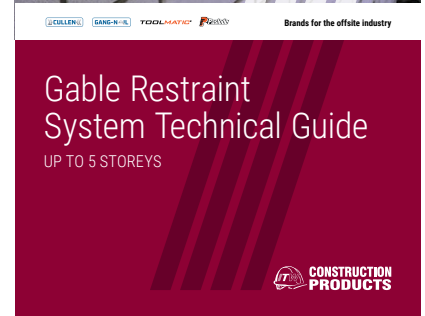

For a Cullen Gable Restraint System Technical Guide please call 01592 117732 or email technical@itwcp.com

8.2 Simpson Strong-Tie gable panel connection

Simpson Strong-Tie has developed a range of products to provide verifiable connection when connecting timber frame gable panels to masonry walls and the roof structure.

The Gable Panel Connector (GPC) has been specifically developed to connect the wall plate to masonry walls, transferring lateral forces between the two components.

The connections have been developed to safely transfer lateral wind loads imposed on the masonry and timber gable ends into the braced roof diaphragm, giving installation options onto a continuous wall plate or raised wall plate.

Either of the installation options meet the minimum requirements of the Building Regulations 2010 approved document A, Scottish Building regulations domestic, NHBC standards for house of five storeys, or less in England and Wales, and four storeys or less in Scotland.

Both the GPC, and the necessary restraint straps, which complete the system, have product acceptance by the NHBC and provide the housebuilder with a robust connection for gable panels. NHBC will require specific project design and details when using these products.

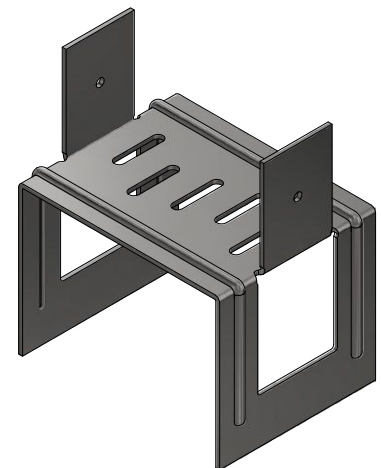

For more details and technical guidance visit www.strongtie.co.uk or call 01827 255600

9 Staying safe

Installing trussed rafters and associated gable wall spandrel panels requires specific construction skills which involve working at height and handling dynamically unstable materials.

The Construction Design and Management (CDM) Regulations require projects to have:

- workers with the right skills, knowledge, training and experience,
- contractors providing appropriate supervision, instruction and information,
- a written construction phase plan.

Visit the CITB website for [more information on understanding CDM](#).

The installation of roof elements including trussed rafters and gable wall spandrel panels should only be undertaken by suitably experienced and qualified personnel, such as those with a Level 2 Diploma in Site Carpentry.

A full written site-specific risk assessment and safe system of work for installation of the trussed rafters and gable panels should be developed and approved by

the principal contractor before any work commences.

Trussed rafters are to be erected and fully braced before gable wall spandrel panels are installed.

Mechanical handling equipment such as a crane or a forklift with suitable adaptations is the preferred method of handling trussed rafters and gable wall spandrel panels.

Safety Checklist:

- Ensure scaffolding is in place and signed off.
 - A safe working platform within the structure is strongly recommended.
 - Ensure hop-ups and scaffolding edge protection are in place.
 - Ensure all personal protective equipment (PPE) is worn and correctly fitted.
 - Check and read all assembly drawings and information provided by the truss supplier.
 - Always follow the site-specific written construction phase plan.
- After reading the truss layout drawings, identify the easiest starting point using the simplest roof of trusses.
 - Consult the site-specific safe system of work before any roof work commences.
 - Once the trussed rafters are erected and their permanent bracing is completely and fully fixed then the gable wall spandrel panels can be installed.
 - Gable wall spandrel panels should be permanently restrained as soon as they are installed. Unrestrained panels will pose an immediate risk to site workers and others.

All images in this guide are for illustrative purposes only. The recommendations given are supplied in good faith but without liability. Their use shall be entirely at the risk of the user.



**TRUSSED RAFTER
ASSOCIATION**

Visit our website for more information: tra.org.uk or traireland.ie

The Building Centre
26 Store Street
London
WC1E 7BT

T: 020 3205 0032
E: info@tra.org.uk

The latest version of this guide can be downloaded online at tra.org.uk or traireland.ie

All information is correct at the date this guide was produced. We reserve the right to make technical changes at any time.